



**FRESH 'N REBEL**

PRODUCT NUMBER:  
3HP4500 v1 001

**CLAM ELITE**  
QUICK START MANUAL

Hereby, Sitecom declares that this radio equipment is in compliance with Directive 2014/53/EU.  
The full text of the EU declaration of conformity is available at the following internet address: [www.freshnrebel.com](http://www.freshnrebel.com)  
Operating frequency band: 2400 to 2483.5 MHz. Maximum radio-frequency power transmitted: 6.52 dBm / 4.49 mW

Sitecom verklaart hierbij dat dit radioapparaat voldoet aan de richtlijn 2014/53/EU.  
De volledige tekst van de EG-verklaring van overeenstemming is beschikbaar op: [www.freshnrebel.com](http://www.freshnrebel.com)  
Gebruikte frequentieband: 2400 tot 2483.5 MHz. Maximaal uitgezonden radiofrequentievermogen: 6.52 dBm / 4.49 mW

Hiermit erklärt Sitecom, dass der Funkanlagentyp der Richtlinie 2014/53/EU entspricht.  
Der vollständige Text der EU-Konformitätserklärung ist unter der folgenden Internetadresse verfügbar: [www.freshnrebel.com](http://www.freshnrebel.com)  
Betriebsfrequenzband: 2400 bis 2483.5 MHz. Maximale übertragene HF-Leistung: 6.52 dBm / 4.49 mW

Sitecom dichiara che questa apparecchiatura radio è conforme alla Direttiva 2014/53/UE.  
Il testo completo della dichiarazione di conformità UE è disponibile al seguente indirizzo Internet: [www.freshnrebel.com](http://www.freshnrebel.com)  
Banda di frequenza di funzionamento: da 2400 a 2483.5 MHz. Potenza massima delle frequenze radio trasmesse: 6.52 dBm / 4.49 mW

Por la presente, Sitecom declara que este equipo de radio cumple con la normativa europea 2014/53/EU.  
El texto completo de la declaración UE de conformidad está disponible en la siguiente dirección de internet: [www.freshnrebel.com](http://www.freshnrebel.com)  
Banda de frecuencia de funcionamiento: 2400 a 2483.5 MHz. Potencia de radiofrecuencia máxima transmitida: 6.52 dBm / 4.49 mW

A Sitecom vem por este meio declarar que este equipamento de rádio cumpre o disposto na Diretiva 2014/53/UE.  
A versão integral da declaração de conformidade da UE está disponível na internet no seguinte endereço: [www.freshnrebel.com](http://www.freshnrebel.com)  
Banda de frequência de funcionamento: 2400 a 2483.5 MHz. Potência de radiofrequência máxima transmitida: 6.52 dBm / 4.49 mW

Sitecom déclare par la présente que cet équipement radioélectrique est en conformité avec la Directive 2014/53/UE.  
Le texte intégral de la déclaration de conformité de l'UE est disponible à l'adresse internet suivante : [www.freshnrebel.com](http://www.freshnrebel.com)  
Bande de fréquences opérationnelle : 2400 à 2483.5 MHz. Puissance fréquence radio maximale transmise : 6.52 dBm / 4.49 mW

Firma Sitecom niniejszym oświadcza, że urządzenie radiowe spełnia wymagania dyrektywy 2014/53/UE.  
Pełny tekst deklaracji zgodności UE dostępny jest pod adresem internetowym: [www.freshnrebel.com](http://www.freshnrebel.com)  
Pasma częstotliwości pracy: 2400 do 2483.5 MHz. Maksymalna moc nadawanego sygnału radiowego: 6.52 dBm / 4.49 mW

Prin prezenta, Sitecom declară că acest echipament radio este în conformitate cu prevederile Directivei 53/2014 UE.  
Textul complet al declarației de conformitate UE este disponibil la următoarea adresă de internet: [www.freshnrebel.com](http://www.freshnrebel.com)  
Bandă de frecvență de funcționare: 2400 - 2483.5 MHz. Putere maximă de frecvență radio transmisă: 6.52 dBm / 4.49 mW

Με το παρόν, η Sitecom δηλώνει ότι αυτός ο ραδιοεξοπλισμός συμμορφώνεται με την Οδηγία 2014/53/Ε.  
Το πλήρες κείμενο της δήλωσης συμμόρφωσης για την ΕΕ διατίθεται στην ακόλουθη διεύθυνση Internet: [www.freshnrebel.com](http://www.freshnrebel.com)  
Ζώνη συχνοτήτων λειτουργίας: 2400 έως 2483.5 MHz. Μέγιστη ισχύς μετάδοσης ραδιοσυχνότητας: 6.52 dBm / 4.49 mW

Sitecom настоящим заявляет, что этот продукт соответствует Директиве 2014/53 / EU.  
Полный текст декларации о соответствии ЕС доступен по следующему интернет-адресу: [www.freshnrebel.com](http://www.freshnrebel.com)  
Диапазон рабочих частот: от 2400 до 2483,5 МГц. Максимальная передаваемая мощность радиочастоты: 6,52 дБм / 4,49 мВт

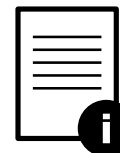

**FRESHREBEL.COM**

## **FIND THE MANUAL IN YOUR OWN LANGUAGE ON OUR WEBSITE**

- NL** Vind de handleiding in je eigen taal op onze website
- DE** Auf unserer Website findest du ein Handbuch in deiner Sprache
- IT** Cerca il manuale nella tua lingua sul nostro sito Web
- ES** En nuestro sitio web podrás encontrar el manual en tu idioma
- PT** Podes encontrar o manual no teu idioma no nosso site
- FR** Retrouve le mode d'emploi dans ta propre langue sur notre site web
- PL** Instrukcję w swoim języku znajdziesz na naszej stronie
- RO** Găsiți manualul în limba dvs. pe website-ul nostru
- GR** Βρείτε το εγχειρίδιο στη γλώσσα σας στην τοποθεσία μας στο Web
- RU** Найдите руководство на вашем родном языке на нашем сайте

# BUTTONS

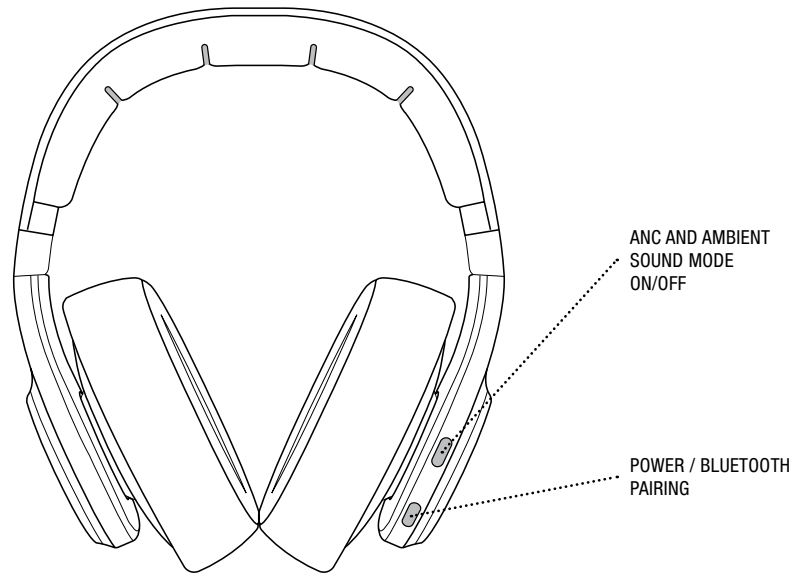

# LEDS

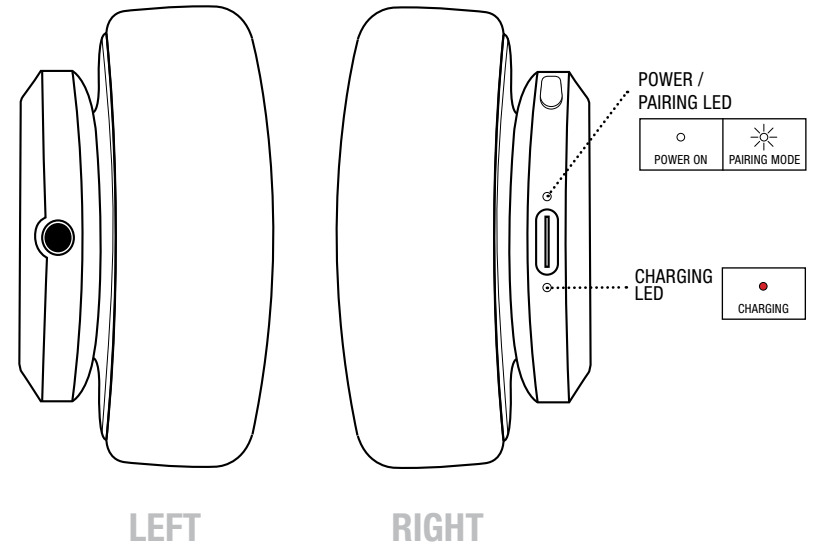

# GETTING STARTED

1.

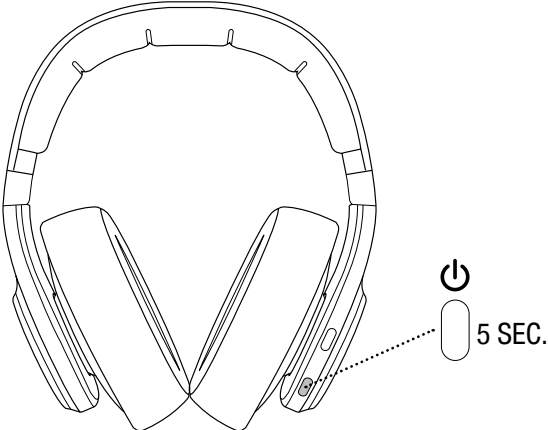

3.

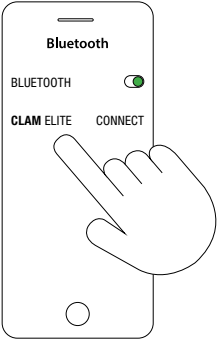

2.

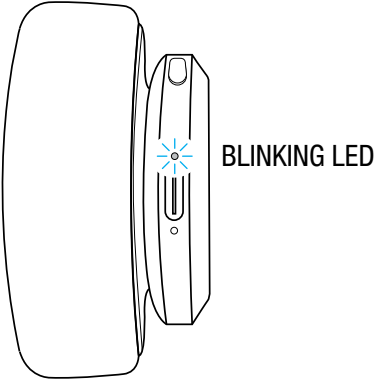

4.

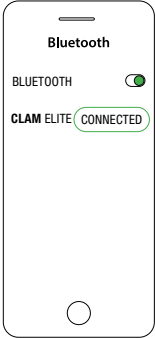

# OPERATION

## GENERAL USE - OPERATING ANC

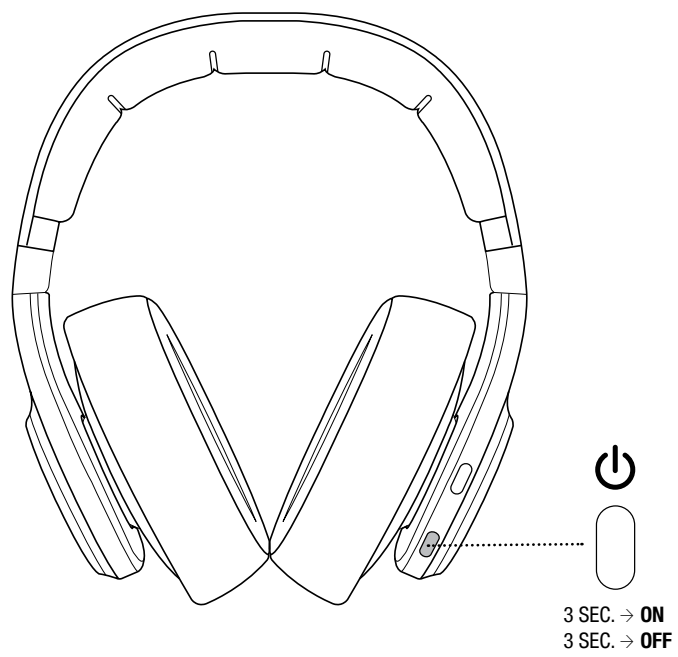
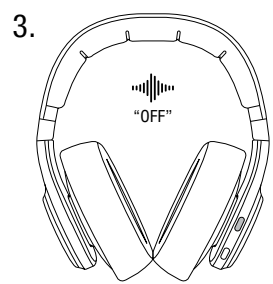
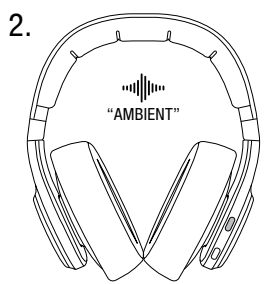
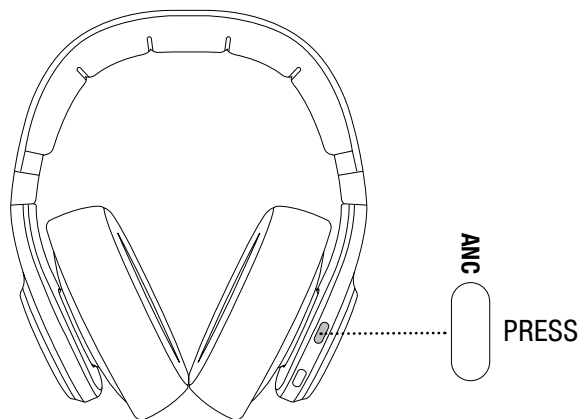

# MUSIC & PHONE CALLS

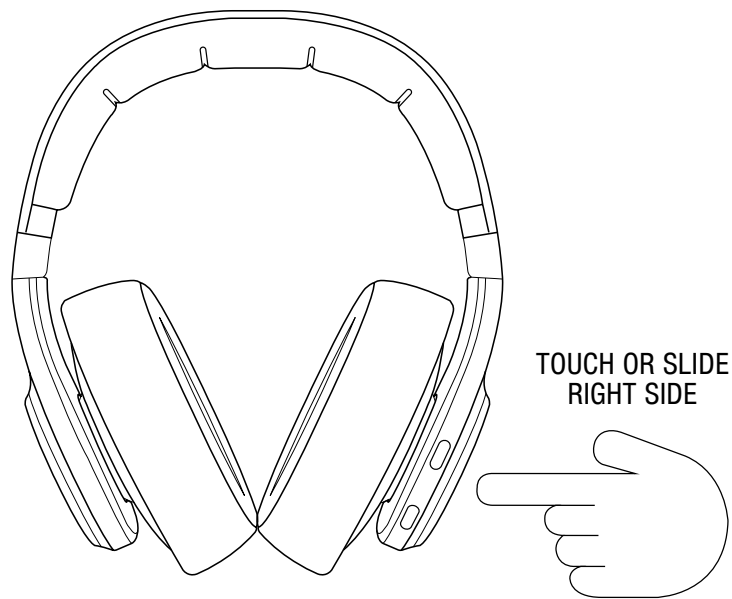

## MUSIC

## PHONE CALLS

## VOICE ASSISTANT

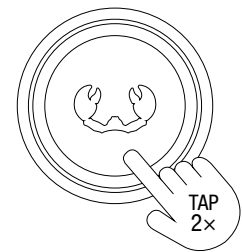

PLAY / PAUSE

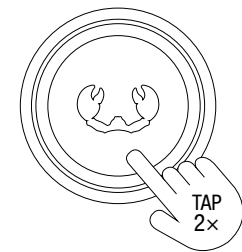

TAKE CALL



VOICE ASSISTANT

VOLUME UP

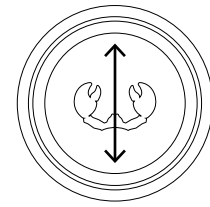

VOLUME DOWN

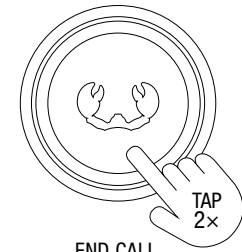

END CALL

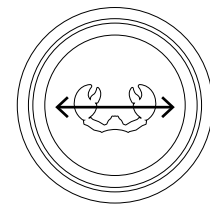

PREVIOUS / NEXT

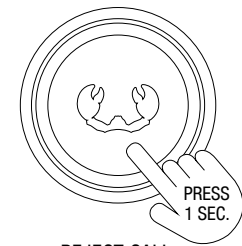

REJECT CALL

## KNOPPEN

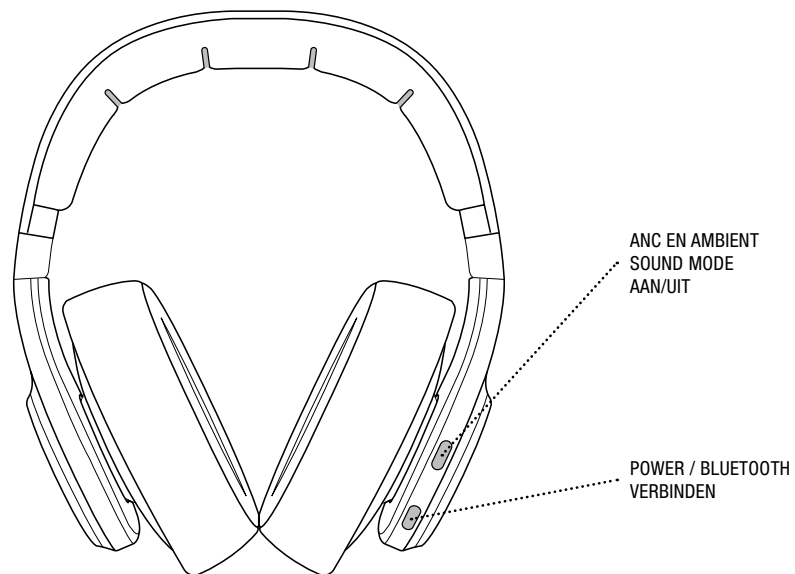

## LEDS

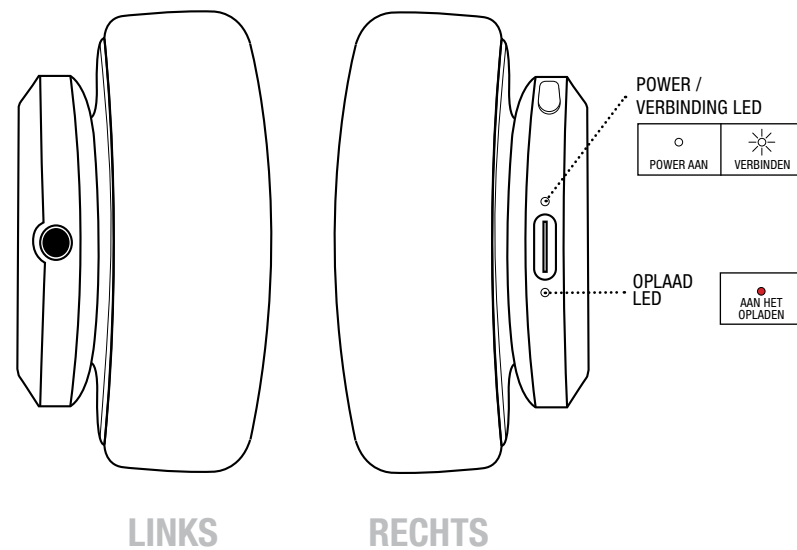

## AAN DE SLAG

1.

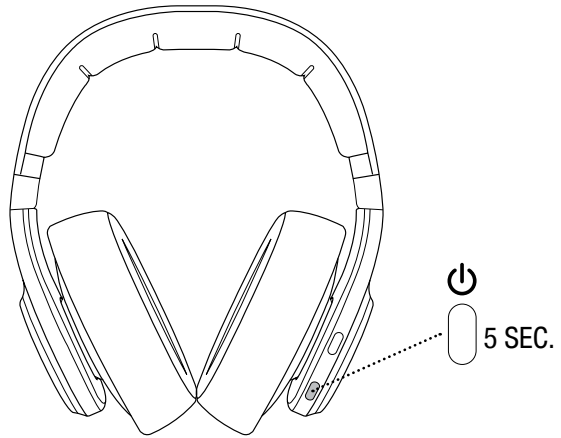

3.

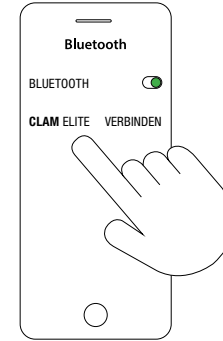

2.

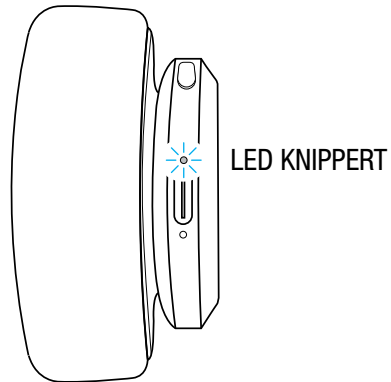

4.

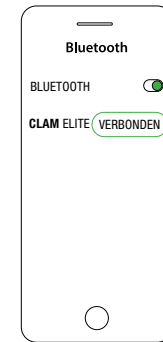



## ALGEMEEN - ANC BEDIENEN

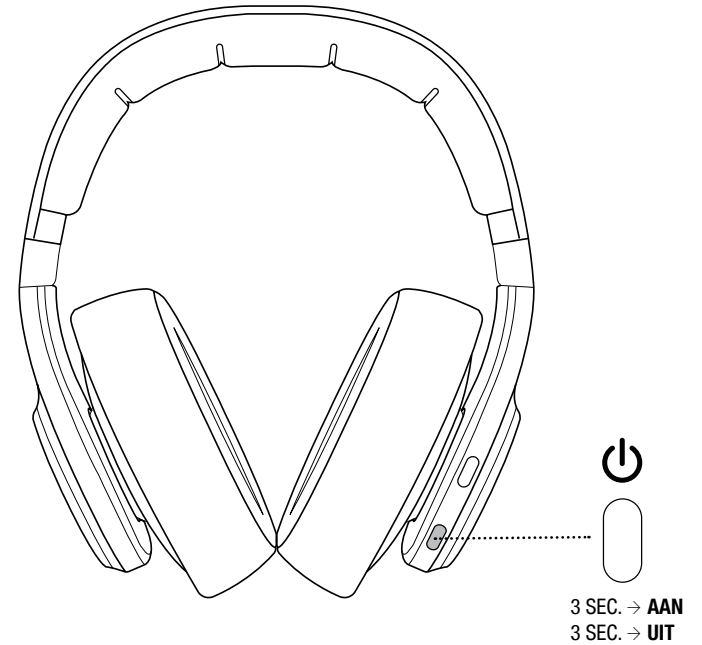
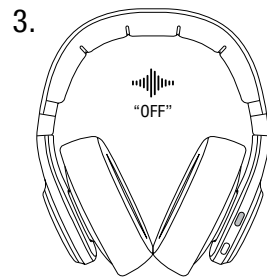
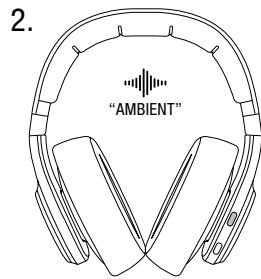
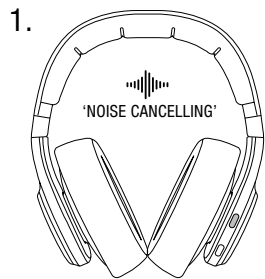
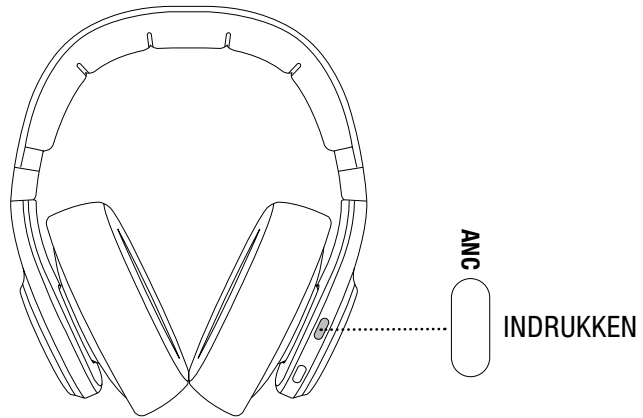

# MUZIEK & OPROEPEN

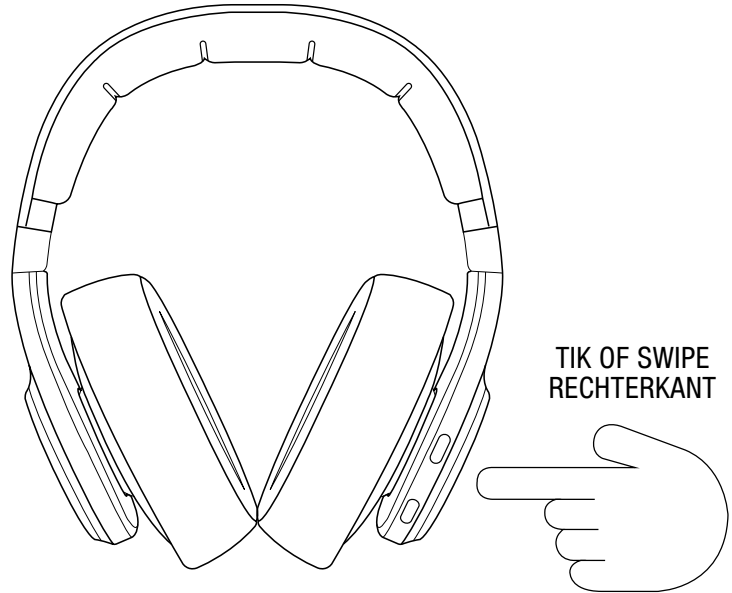

## MUZIEK

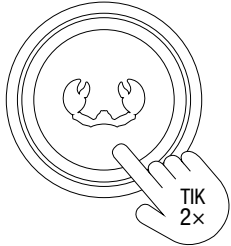

PLAY / PAUZE

## OPROEPEN

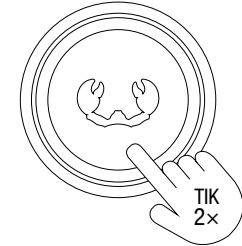

OPROEP BEANTWOORDEN

## SPRAAKASSISTENT



SPRAAKASSISTENT

## VOLUME OMHOOG

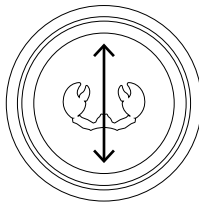

VOLUME OMLAAG

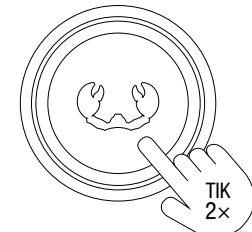

OPROEP BEËNDIGEN

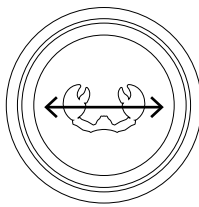

VORIGE / VOLGENDE



OPROEP AFWIJZEN

# TASTEN

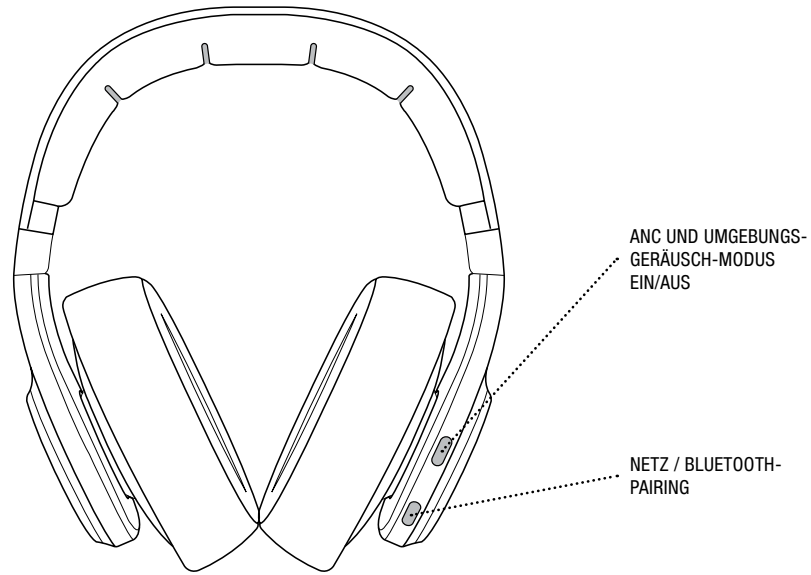

# LEDs

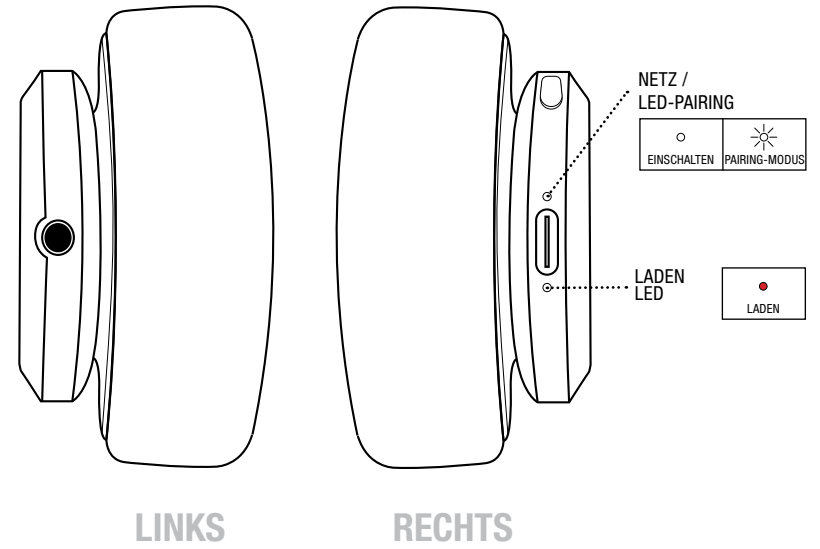

# INBETRIEBNAHME

1.

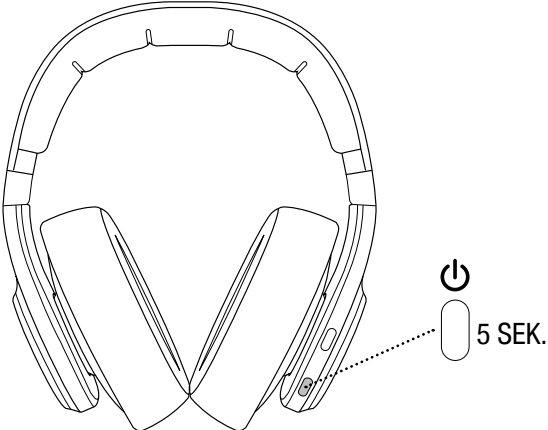

3.

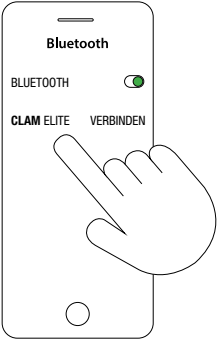

2.

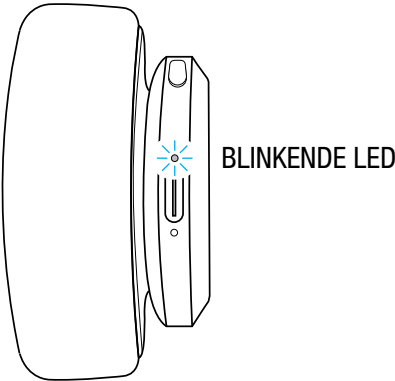

4.



## ALLGEMEINE VERWENDUNG — ANC BEDIENEN

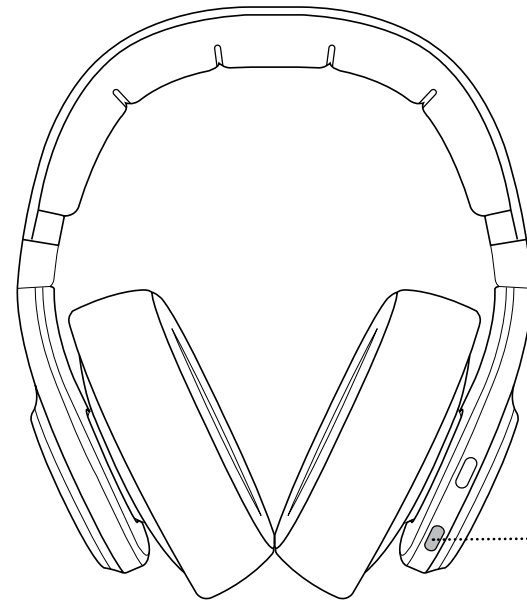
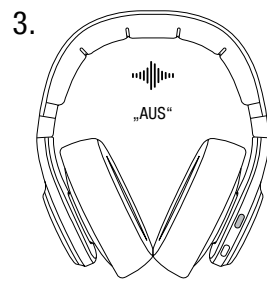
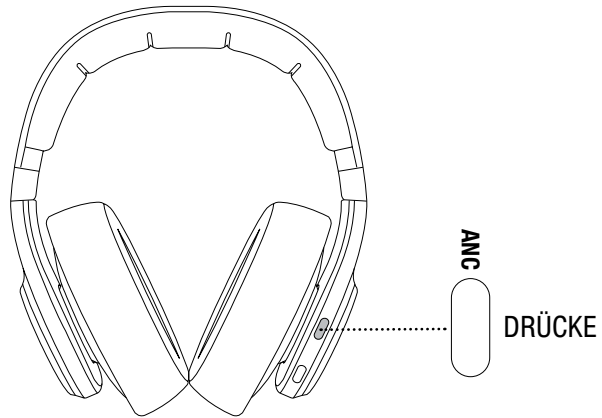

3 SEK. → EIN  
3 SEK. → AUS

# MUSIK UND TELEFONATE

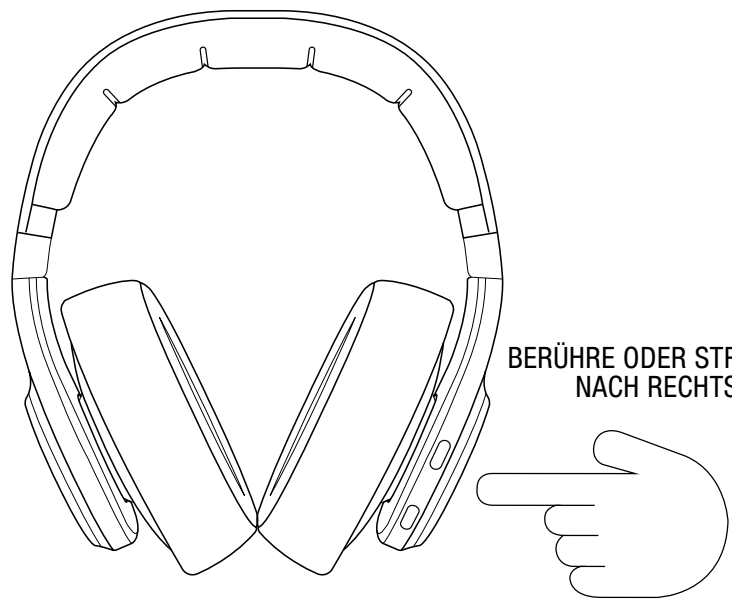

BERÜHRE ODER STREICHE NACH RECHTS

## MUSIK

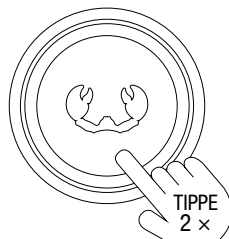

WIEDERGABE / PAUSE

LAUTSTÄRKE ERHÖHEN

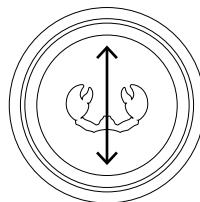

LAUTSTÄRKE REDUZIEREN

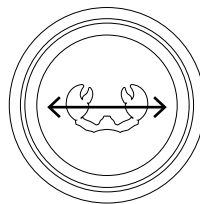

ZURÜCK / WEITER

## TELEFONATE

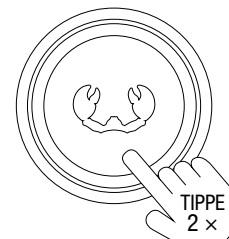

ANRUF ANNEHMEN

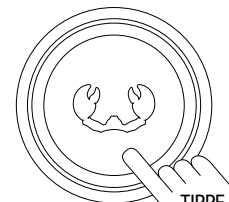

ANRUF BEENDEN

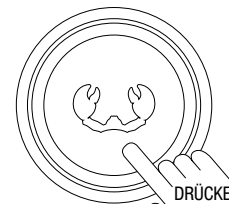

ANRUF ABLEHNEN

## SPRACHASSISTENT

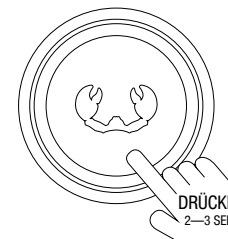

SPRACHASSISTENT

TIPPE 2 x

TIPPE 2 x

DRÜCKE 2-3 SEK.

TIPPE 2 x

DRÜCKE 1 SEK.

# PULSANTI

# LED

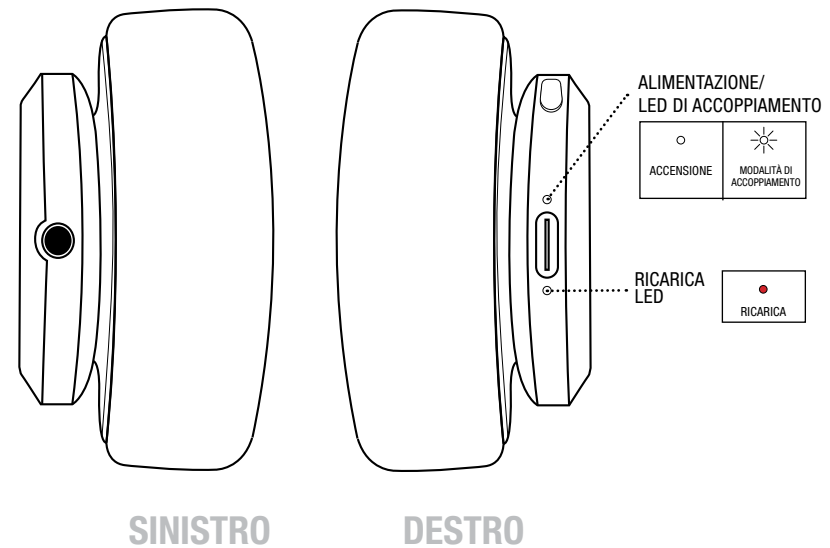
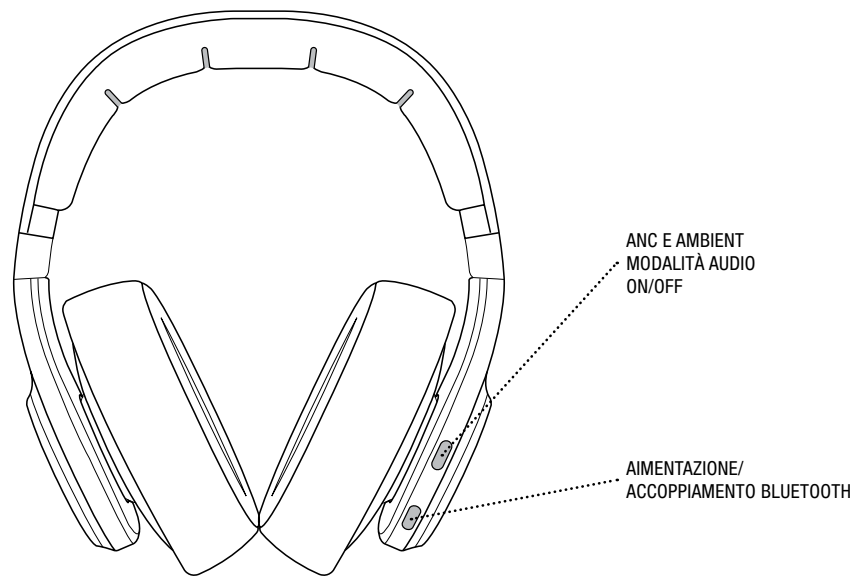

# GUIDA INTRODUTTIVA

1.

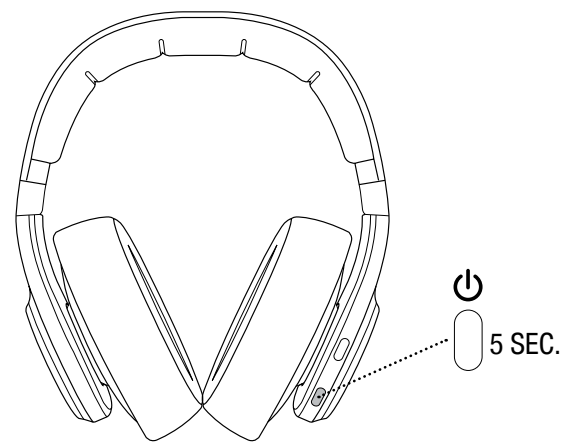

3.

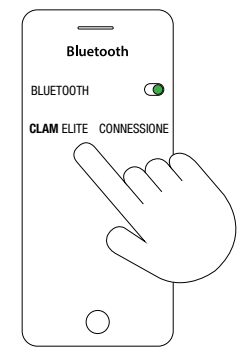

2.

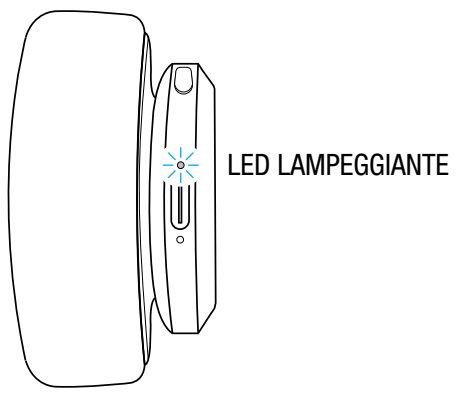

4.

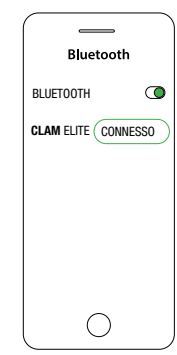



# FUNZIONAMENTO

## USO GENERALE - FUNZIONAMENTO ANC

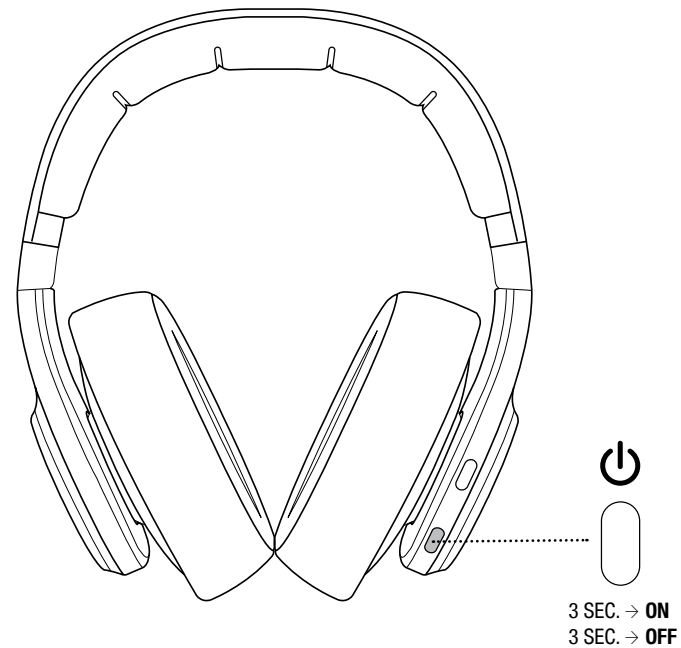
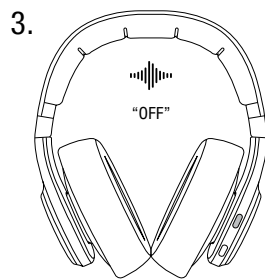
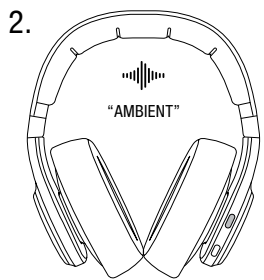
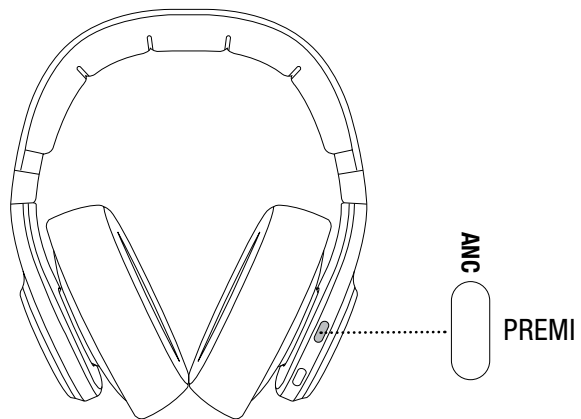

# MUSICA E CHIAMATE TELEFONICHE



## MUSICA

## CHIAMATE TELEFONICHE

## ASSISTENTE VOCALE

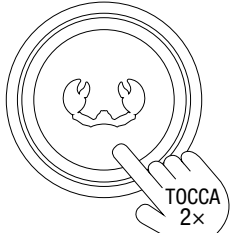

PLAY/PAUSE

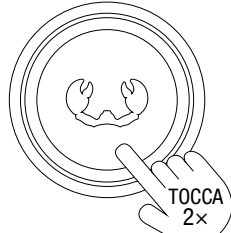

RISPONDI A UNA CHIAMATA

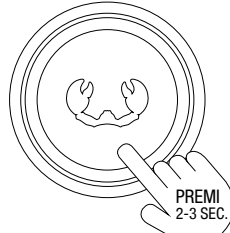

ASSISTENTE VOCALE

AUMENTA IL VOLUME

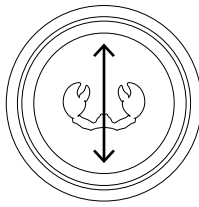

ABBASSA IL VOLUME



METTI FINE ALLA CHIAMATA

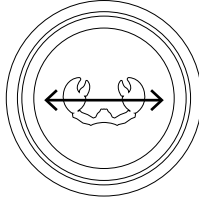

PRECEDENTE/SUCCESSIVO

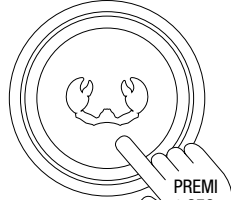

RIFIUTA LA CHIAMATA

# BOTONES

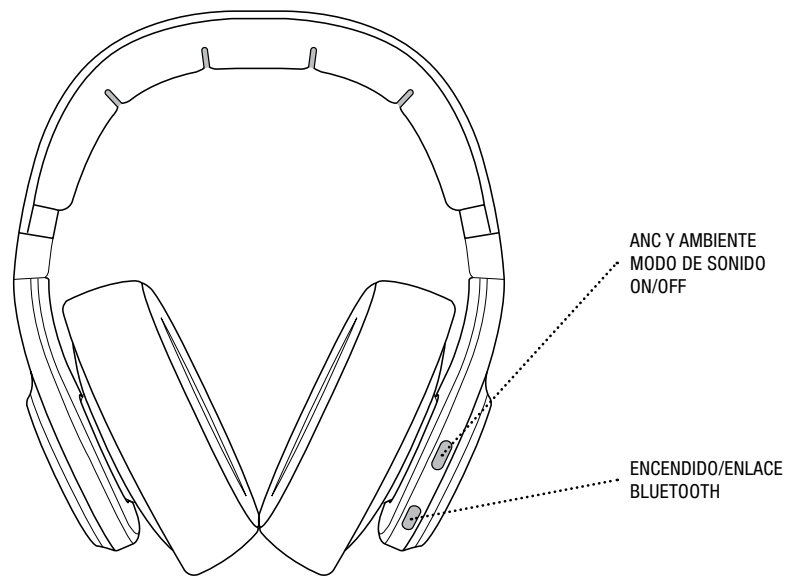

# LEDS

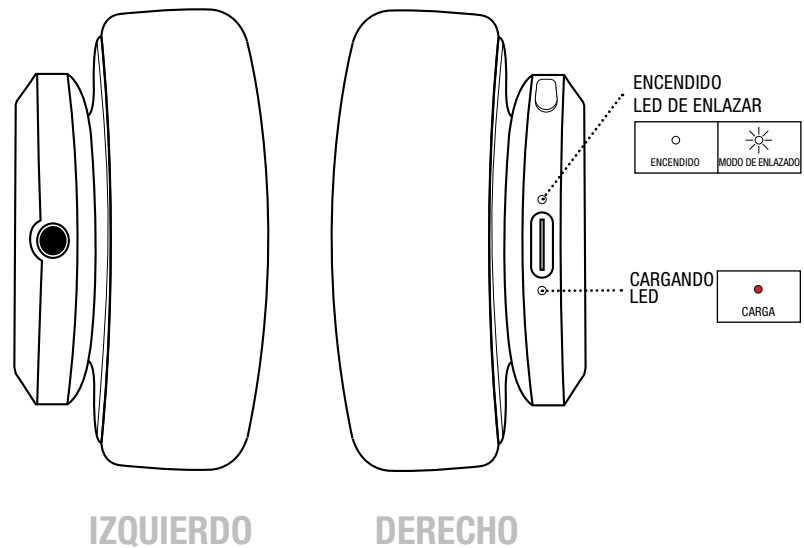

# PRIMEROS PASOS

1.

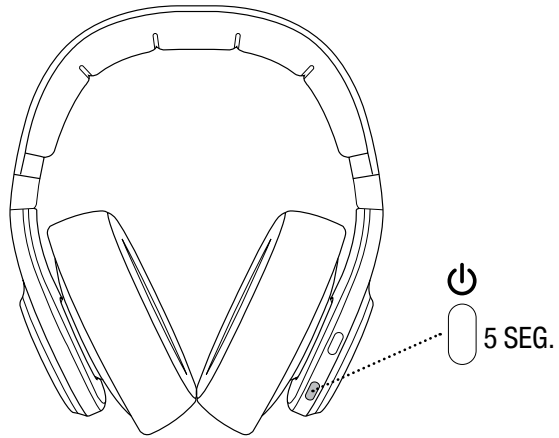

3.

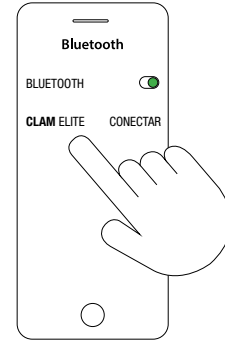

2.

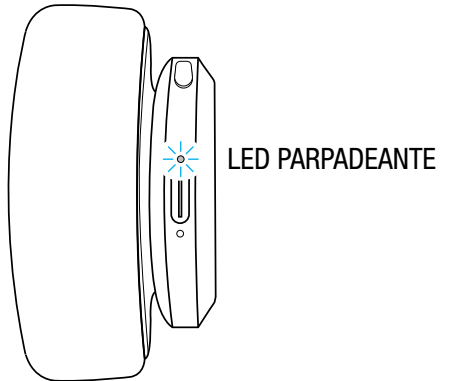

4.



# MANEJO

## USO GENERAL: FUNCIONAMIENTO DE ANC

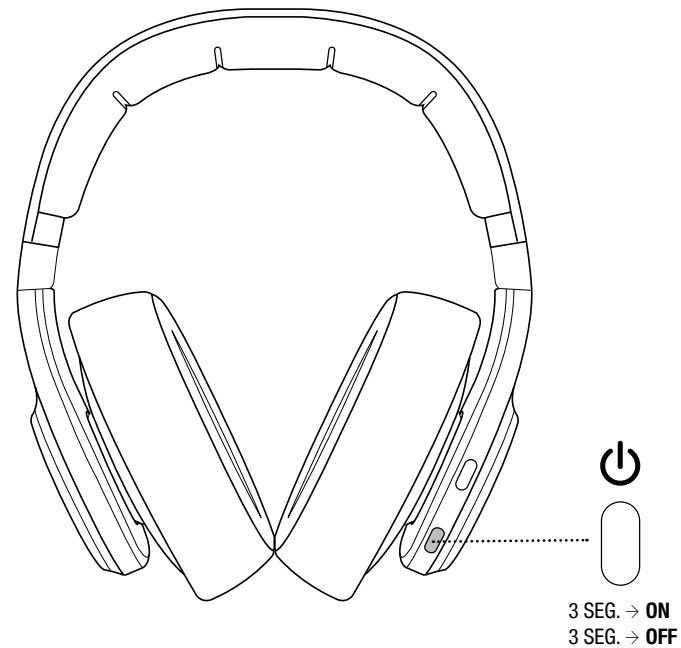
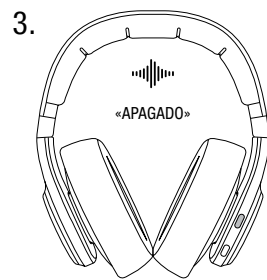
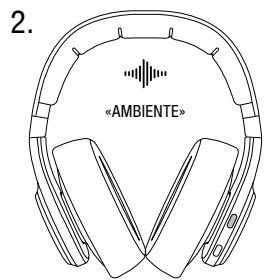
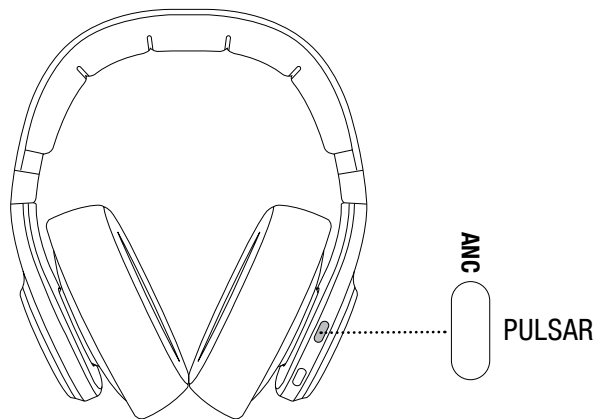

# MÚSICA Y LLAMADAS TELEFÓNICAS



## MÚSICA

## LLAMADAS TELEFÓNICAS

## ASISTENTE DE VOZ

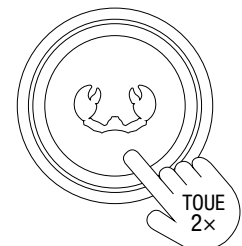

REPRODUCIR/PAUSA

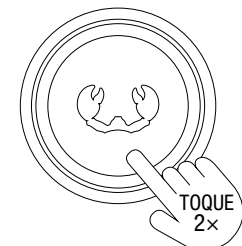

RESPONDER LLAMADA

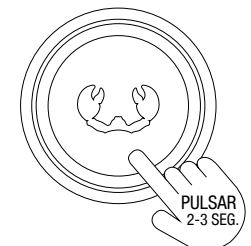

ASISTENTE DE VOZ

SUBIR EL VOLUMEN

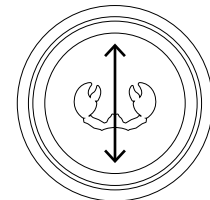

BAJAR VOLUMEN

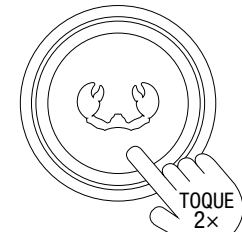

FINALIZAR LLAMADA

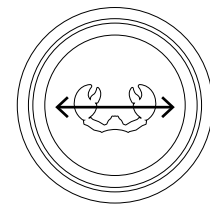

ANTERIOR/SIGUIENTE

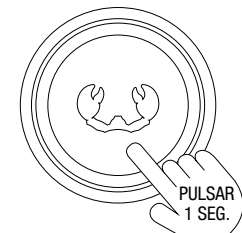

RECHAZAR LLAMADA

# BOTÕES

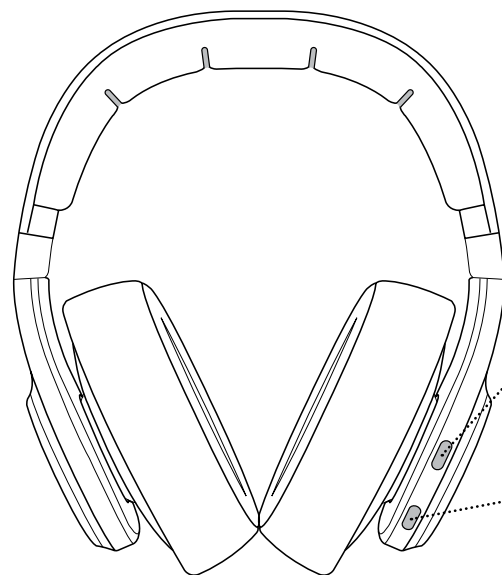

MODO DE SOM  
ANC E AMBIENTE  
LIGAR/DESLIGAR

ALIMENTAÇÃO /  
EMPARELHAMENTO  
POR BLUETOOTH

# LED

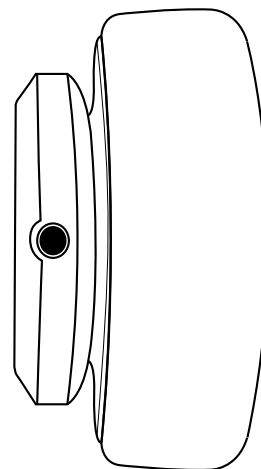

ESQUERDA

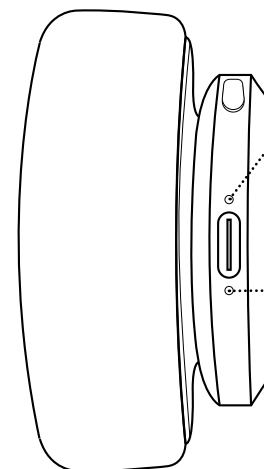

DIREITA

LED DE ALIMENTAÇÃO/  
EMPARELHAMENTO

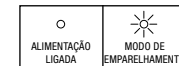

LED DE  
CARGA



# INTRODUÇÃO

1.

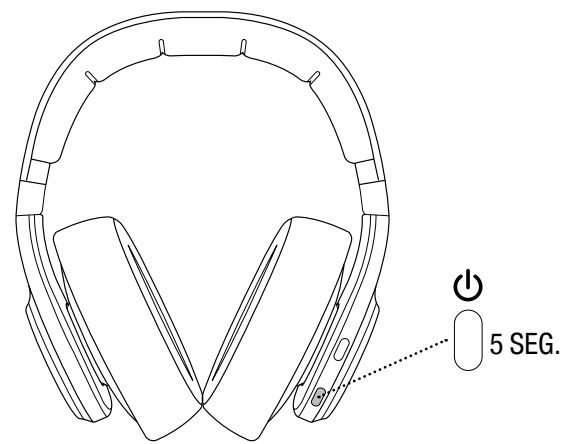

3.

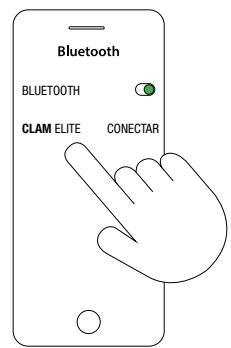

2.

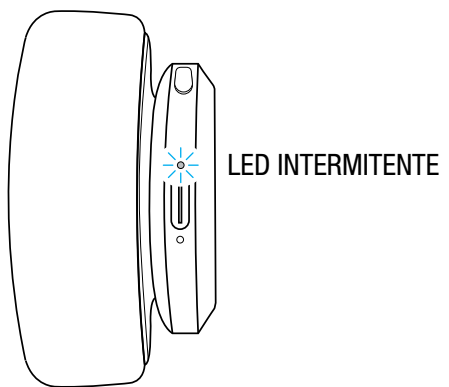

4.





# UTILIZAÇÃO

## UTILIZAÇÃO GERAL - UTILIZAÇÃO DO ANC

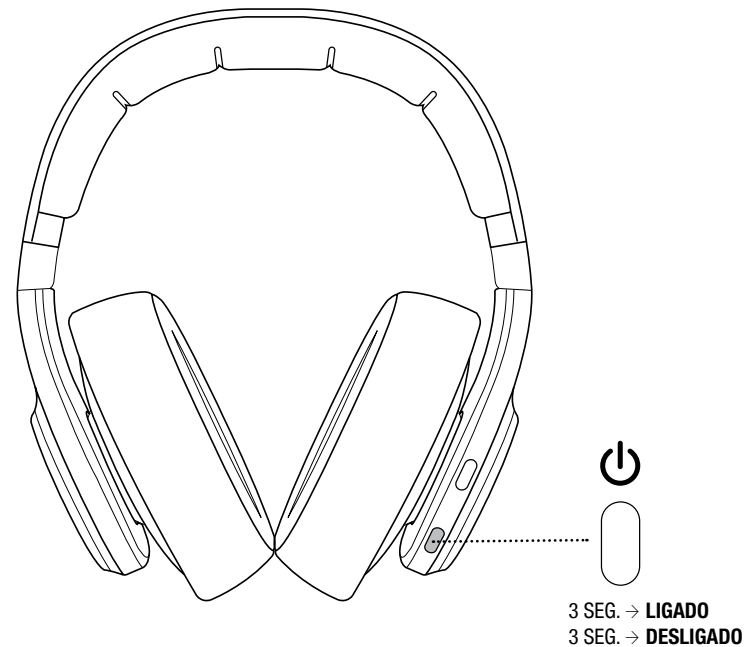
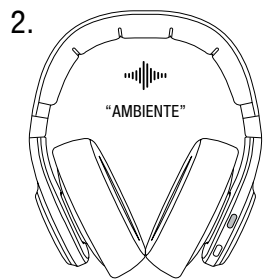
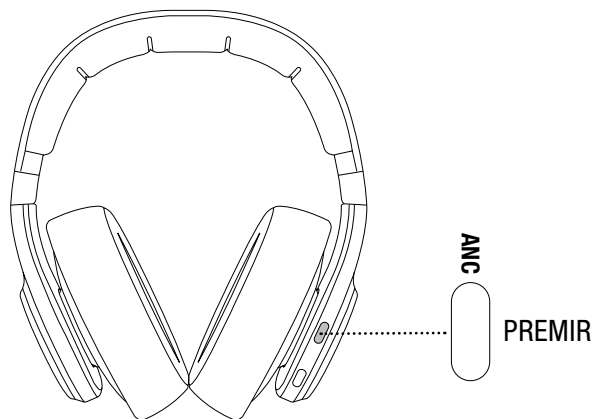

# MÚSICA E CHAMADAS TELEFÓNICAS



## MÚSICA

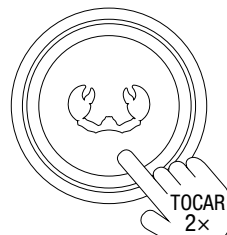

REPRODUZIR / PAUSA

AUMENTAR VOLUME

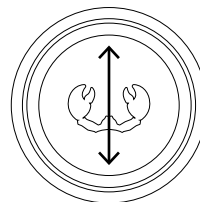

DIMINUIR VOLUME

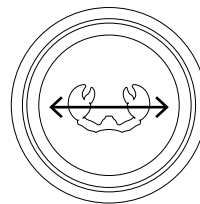

ANTERIOR / SEGUINTE

## CHAMADAS TELEFÓNICAS

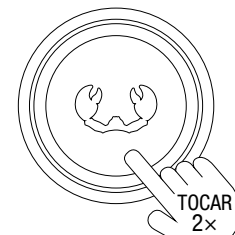

ATENDER CHAMADA

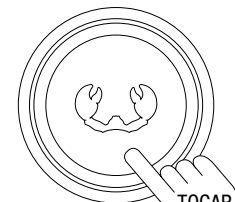

TERMINAR CHAMADA

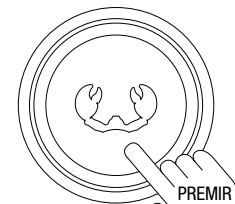

REJEITAR CHAMADA

## ASSISTENTE DE VOZ

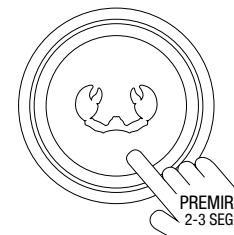

ASSISTENTE DE VOZ

# BOUTONS

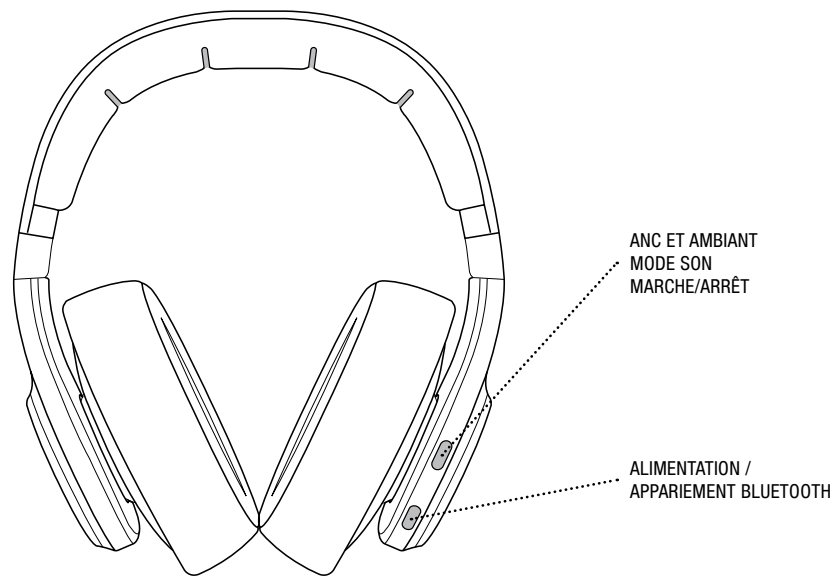

# LED

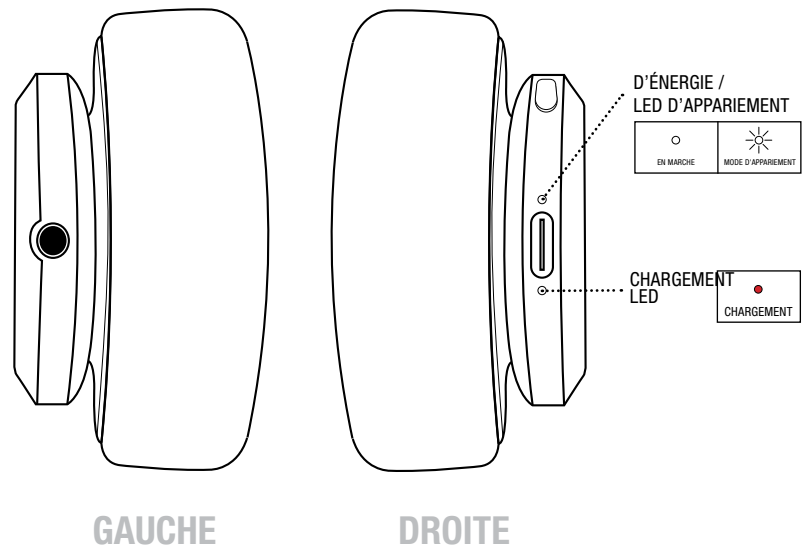

# COMMENCER

1.

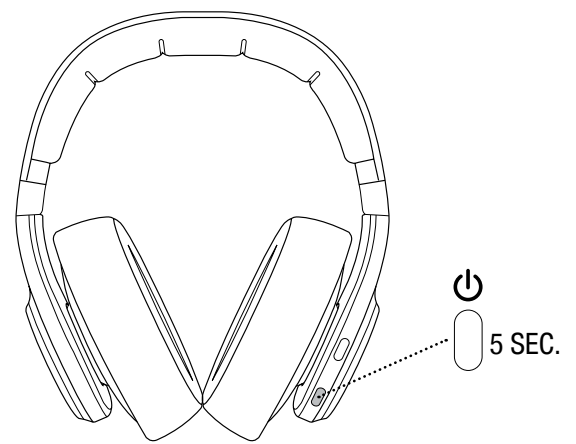

3.

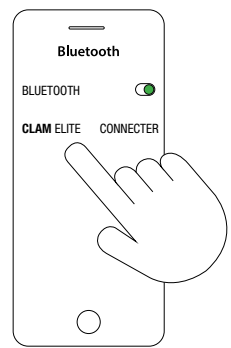

2.

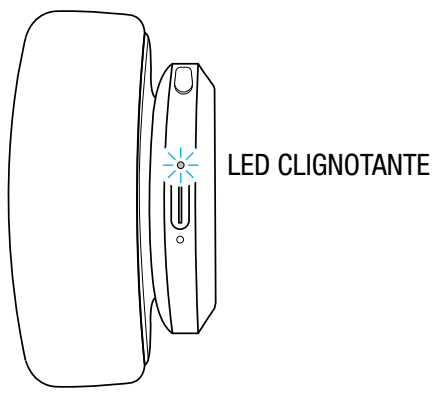

4.



# FONCTIONNEMENT

## UTILISATION GÉNÉRALE - FONCTIONNEMENT EN MODE ANC

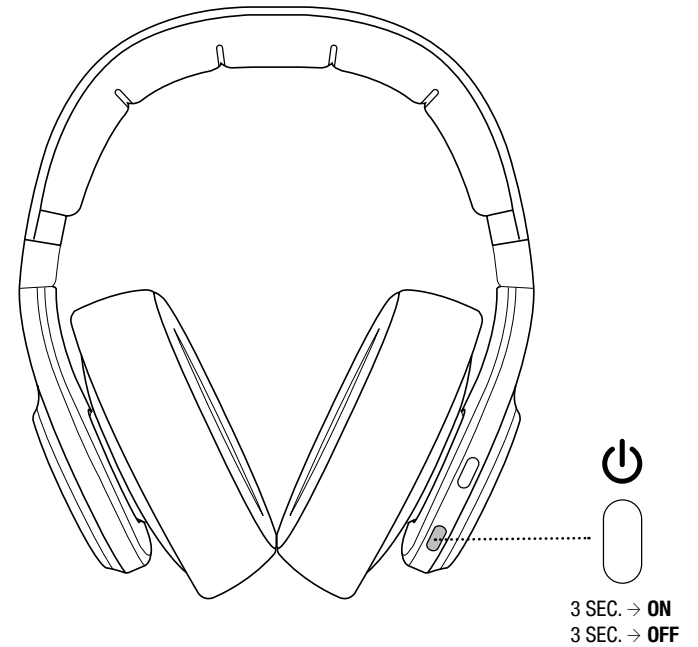
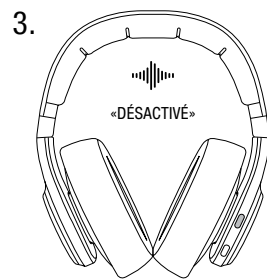
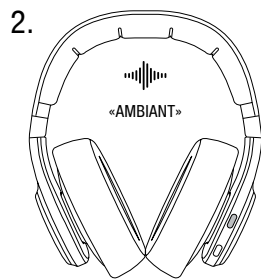
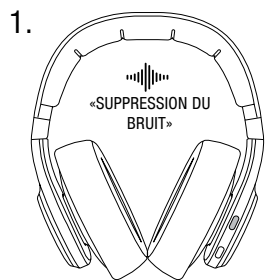
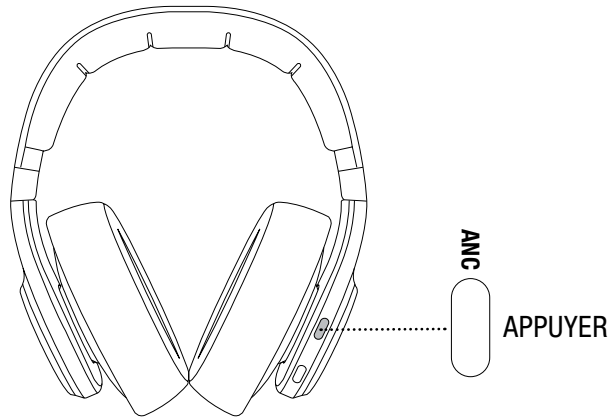

# MUSIQUE & APPELS TÉLÉPHONIQUES

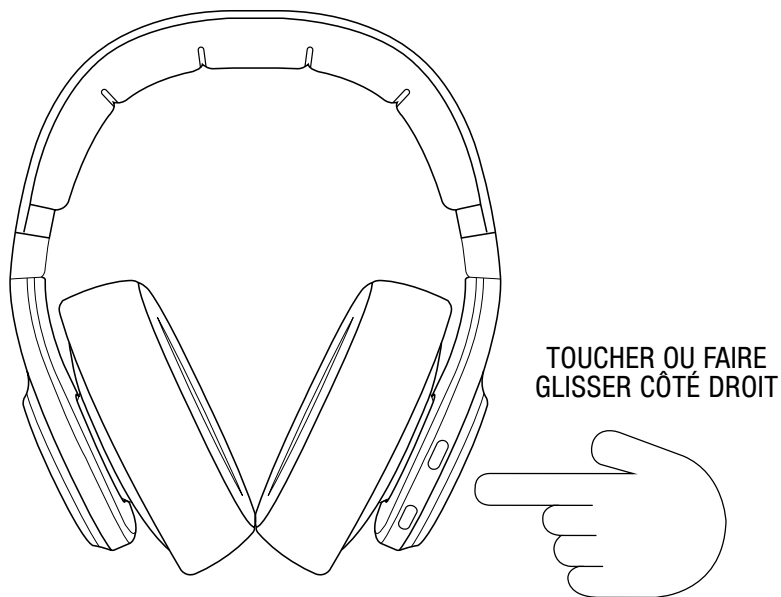

## MUSIQUE

## APPELS TÉLÉPHONIQUES

## ASSISTANT VOCAL

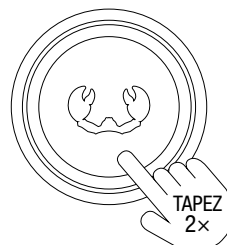

LECTURE / PAUSE

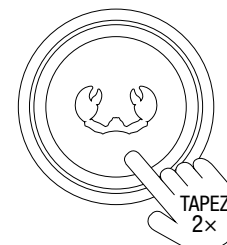

PRENDRE L'APPEL

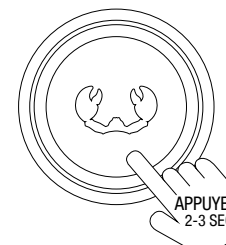

ASSISTANT VOCAL

MONTER LE VOLUME

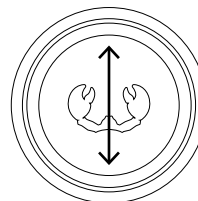

BAISSER LE VOLUME

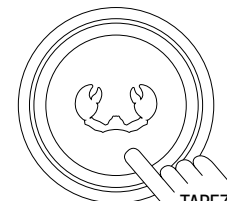

METTRE FIN À L'APPEL

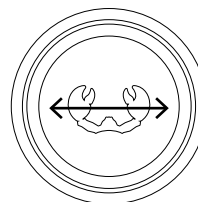

PRÉCÉDENT / SUIVANT

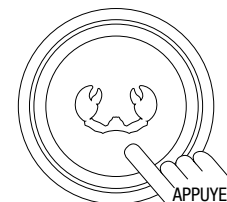

REJETER L'APPEL

## PRZYCISKI

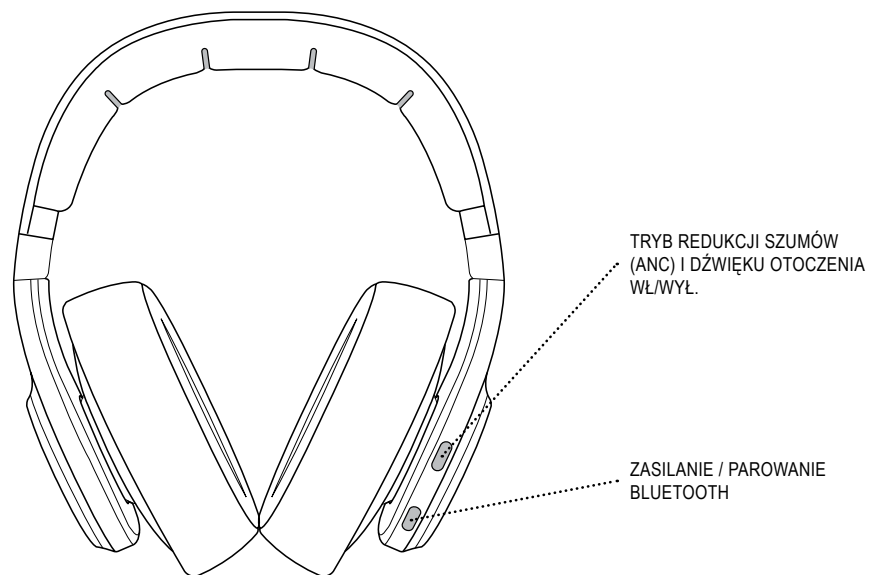

## KONTROLKI LED

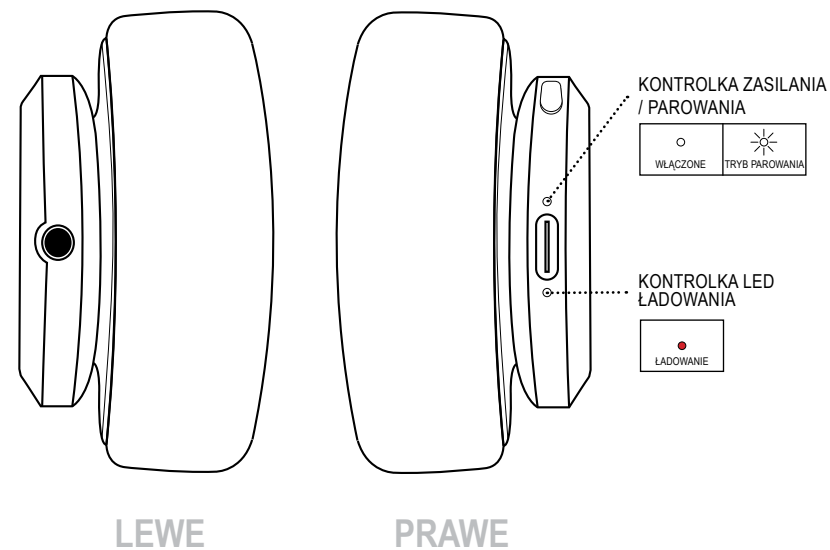

## ROZPOCZYNIANIE UŻYTKOWANIA

1.

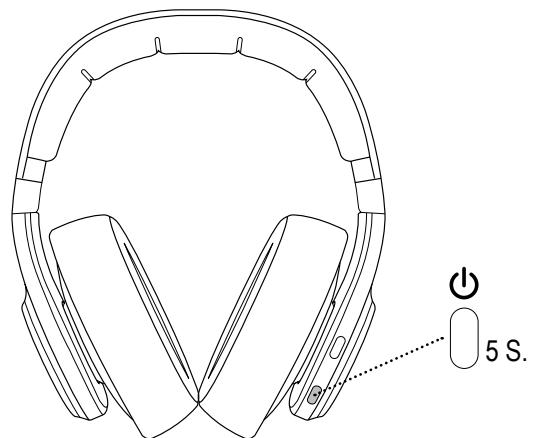

3.

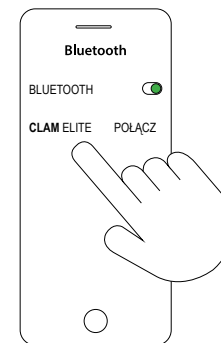

2.

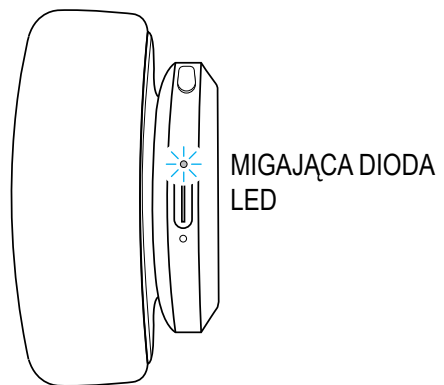

4.

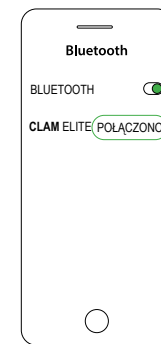



OGÓLNE UŻYTKOWANIE – OBSŁUGA  
TRYBU ANC

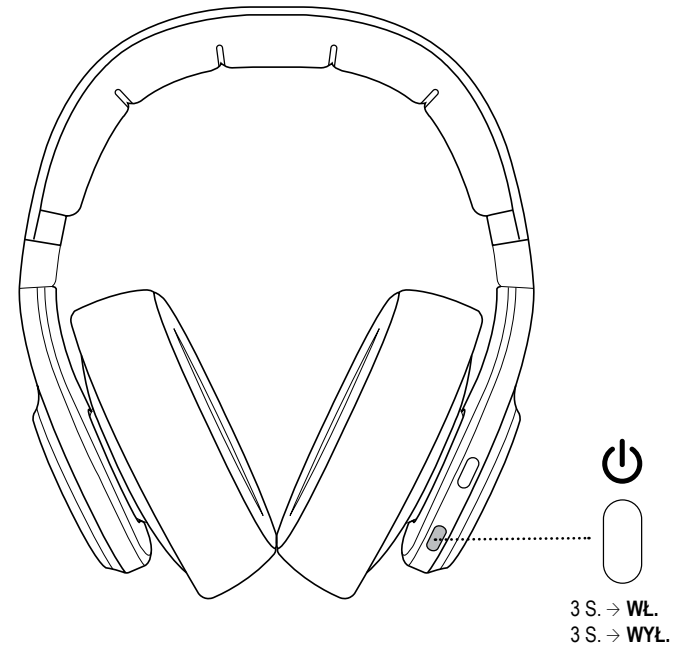
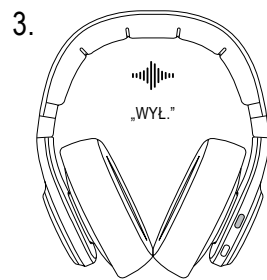
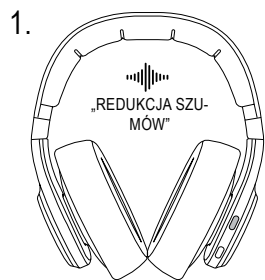
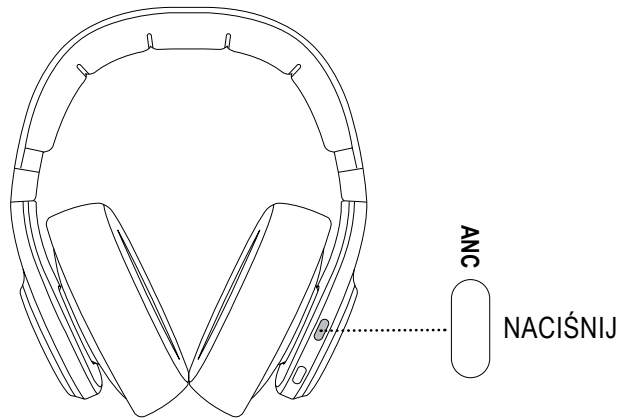

# MUZYKA I POŁĄCZENIA TELEFONICZNE

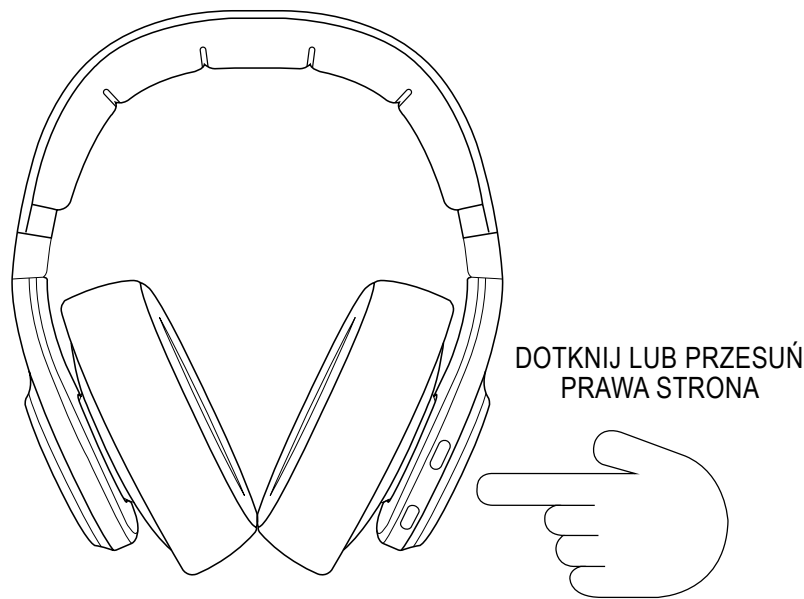

MUZYKA

POŁĄCZENIA TELEFONICZNE

ASYSTENT GŁOSOWY



ODTWARZAJ / PAUZA



ODBIERZ POŁĄCZENIE



ASYSTENT GŁOSOWY

POGŁOŚNIJ

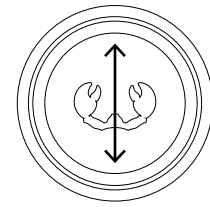

ŚCISZ



ZAKOŃCZ ROZMOWĘ

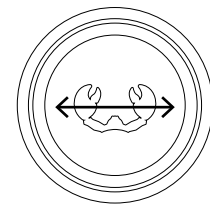

WSTECZ / DALEJ



ODRZUCIĆ POŁĄCZENIE

# BUTOANE

# LED-URI

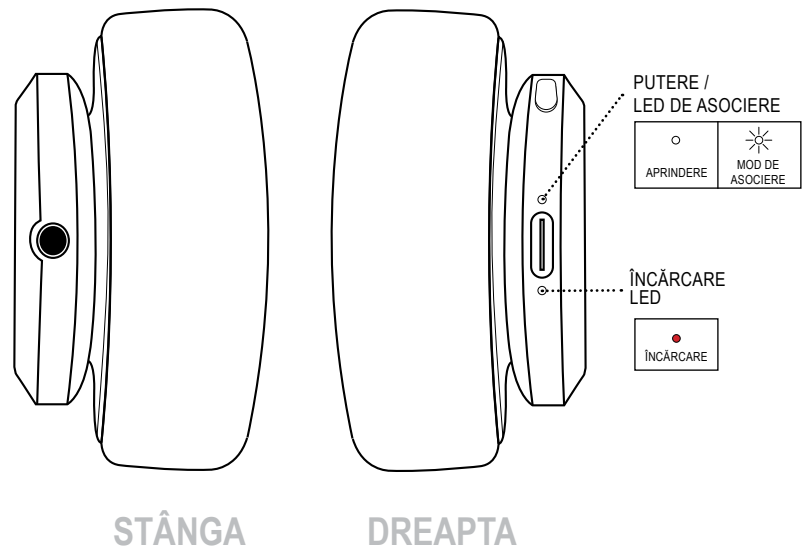
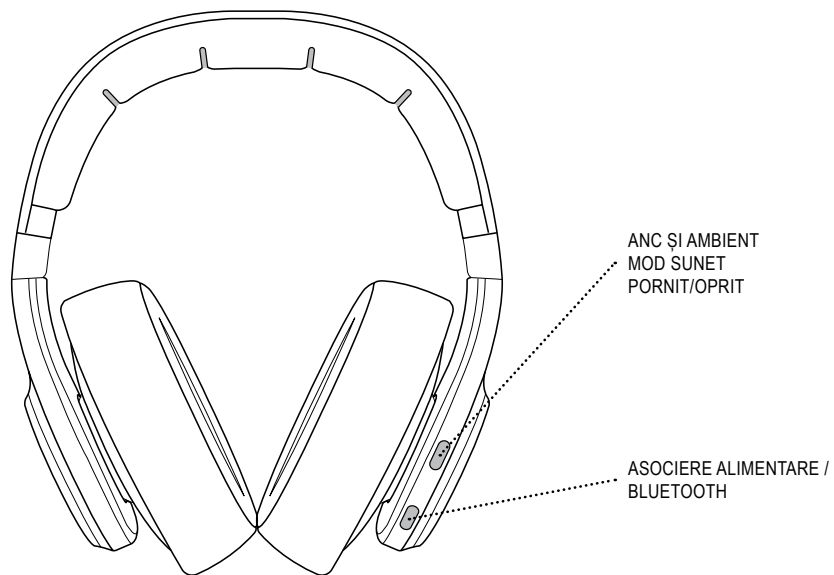

# NOȚIUNI DE BAZĂ

1.

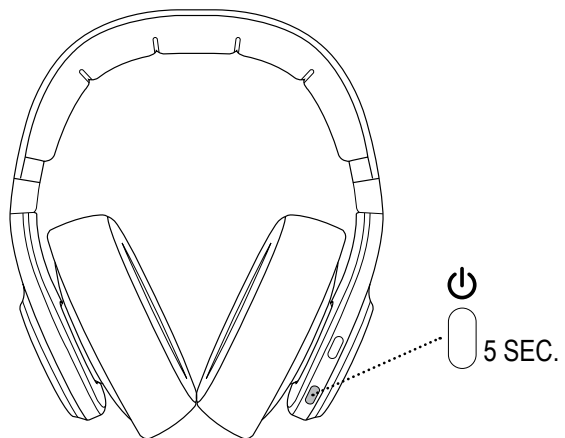

3.

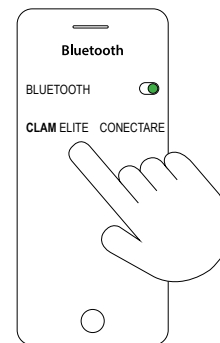

2.

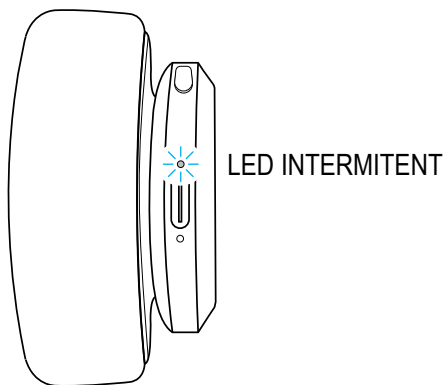

4.



# OPERAȚIUNE

## UTILIZARE GENERALĂ - FUNCȚIONARE ANC

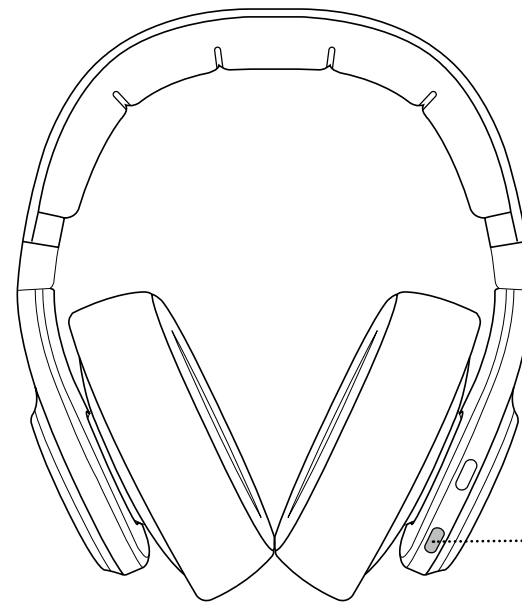
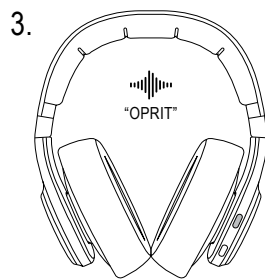
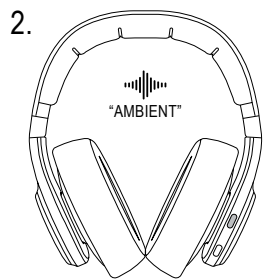
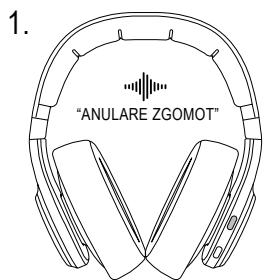
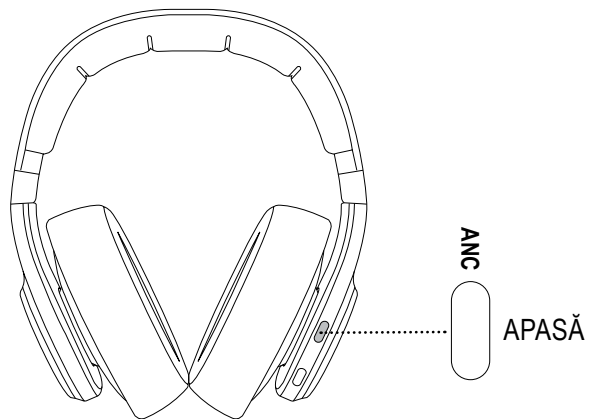

3 SEC. → PORNIT  
3 SEC. → OPRIT

# MUZICĂ & APELURI

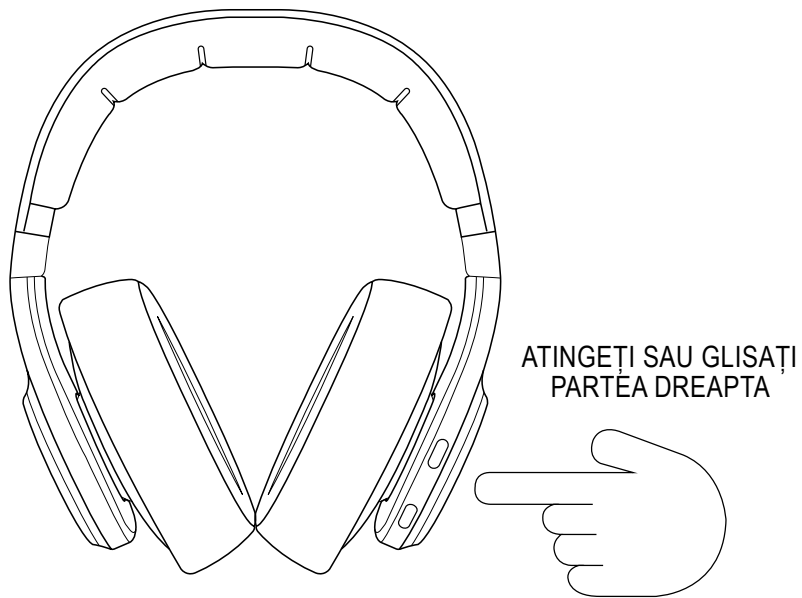

## MUZICĂ

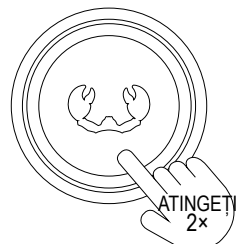

REDARE / PAUZĂ

## APELURI TELEFONICE

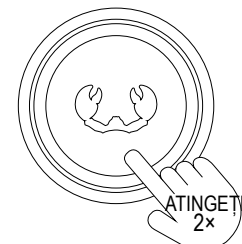

PRELUARE APEL

## ASISTENT VOCAL

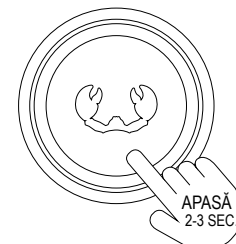

ASISTENT VOCAL

## CREȘTERE VOLUM

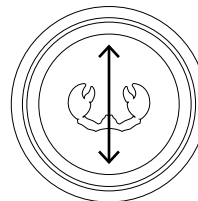

SCĂDERE VOLUM

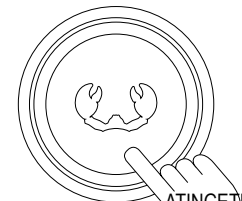

ÎNCHIEIERE APEL

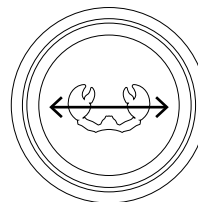

ANTERIOARA / URMĂTOAREA

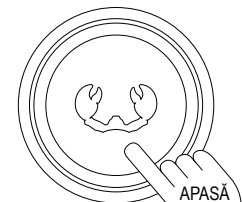

RESPINGERE APEL

# ΚΟΥΜΠΙΑ

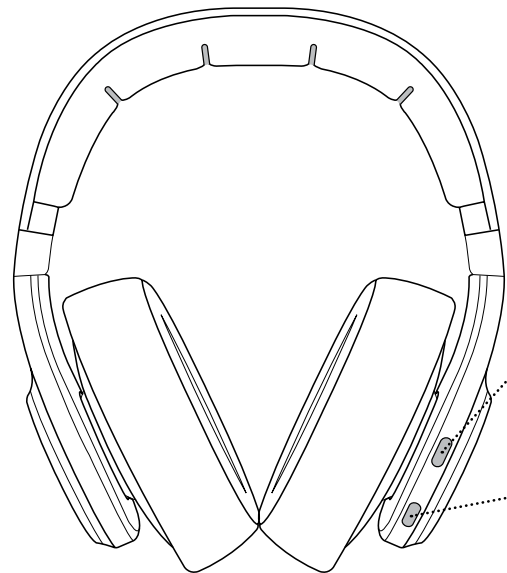

ANC ΚΑΙ ΠΕΡΙΒΑΛΛΟΝ  
ΛΕΙΤΟΥΡΓΙΑ ΗΧΟΥ  
ΕΝΕΡΓΟΠΟΙΗΣΗ /  
ΑΠΕΝΕΡΓΟΠΟΙΗΣΗ

ΣΥΖΕΥΞΗ ΤΡΟΦΟΔΟΣΙΑΣ /  
BLUETOOTH

# ΛΥΧΝΙΕΣ LED

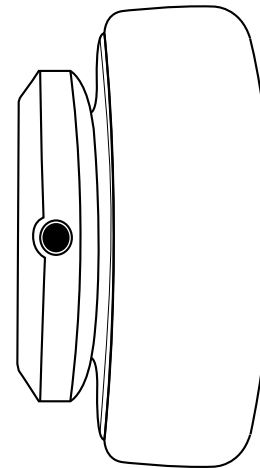

ΑΡΙΣΤΕΡΑ

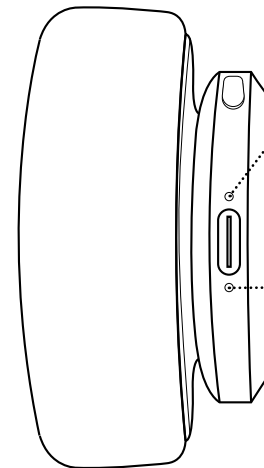

ΔΕΞΙΑ

ΤΡΟΦΟΔΟΣΙΑ /  
ΣΥΖΕΥΞΗ LED



ΦΟΡΤΙΣΗ  
LED



# ΑΣ ΞΕΚΙΝΗΣΟΥΜΕ

1.

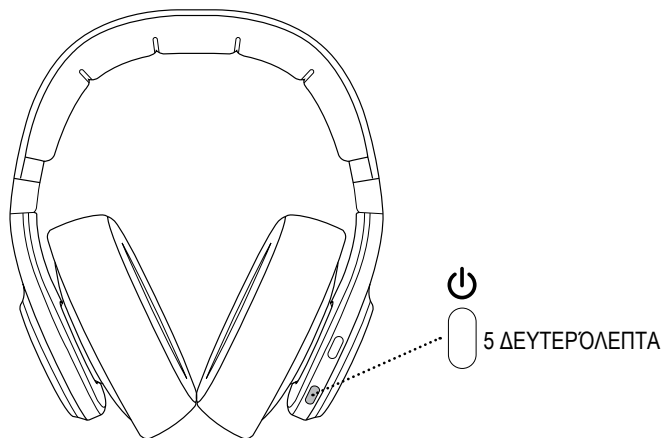

3.

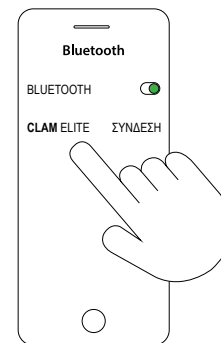

2.

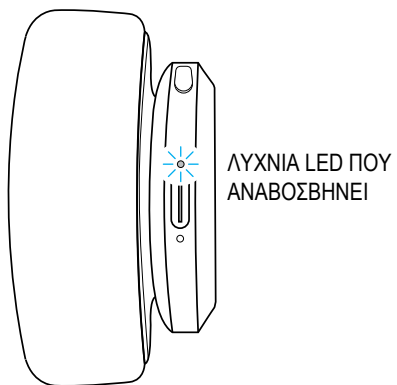

4.

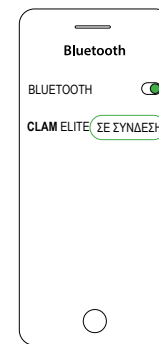



## ΓΕΝΙΚΗ ΧΡΗΣΗ - ΛΕΙΤΟΥΡΓΙΑ ANC

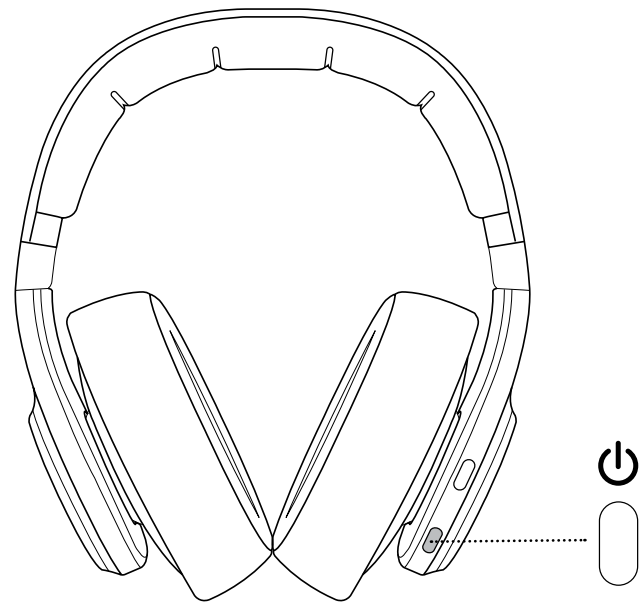
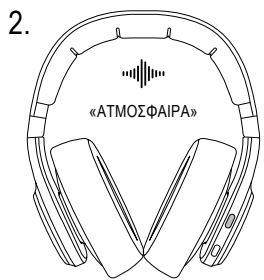
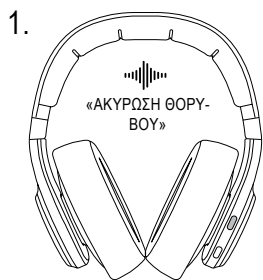
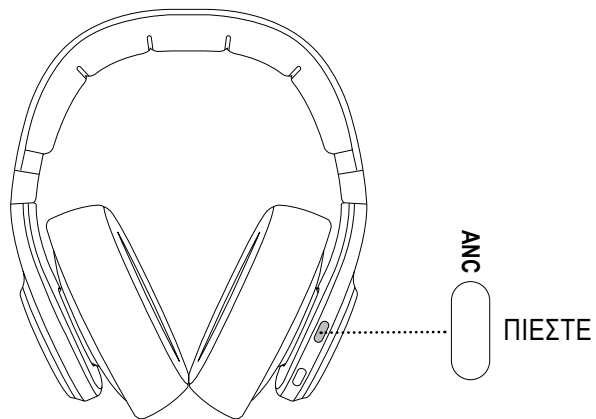

# ΜΟΥΣΙΚΗ ΚΑΙ ΤΗΛΕΦΩΝΙΚΕΣ ΚΛΗΣΕΙΣ

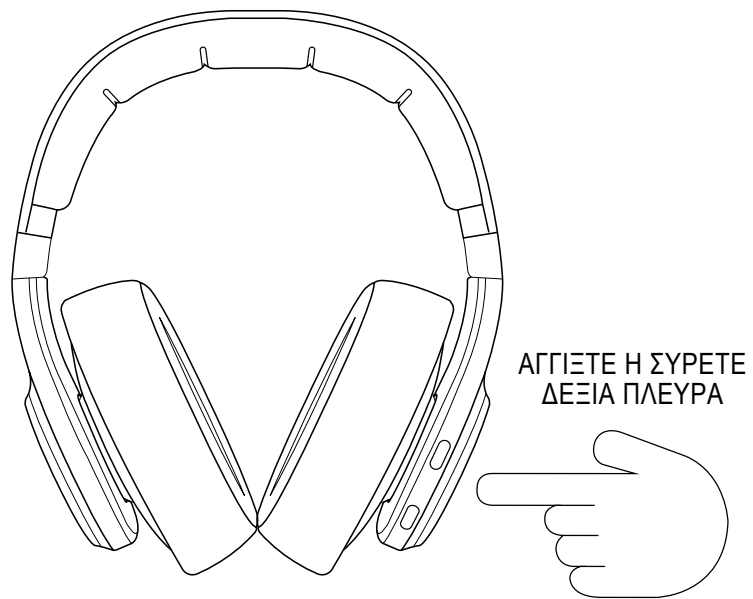

## ΜΟΥΣΙΚΗ

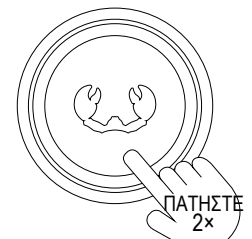

ΑΝΑΠΑΡΑΓΩΓΗ / ΠΑΥΣΗ

## ΤΗΛΕΦΩΝΙΚΕΣ ΚΛΗΣΕΙΣ

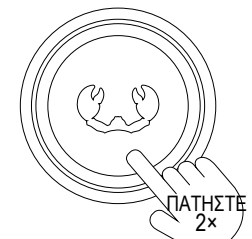

ΑΠΑΝΤΗΣΗ ΚΛΗΣΗΣ

## ΦΩΝΗΤΙΚΟΣ ΒΟΗΘΟΣ



ΦΩΝΗΤΙΚΟΣ ΒΟΗΘΟΣ

## ΑΥΞΗΣΗ ΕΝΤΑΣΗΣ

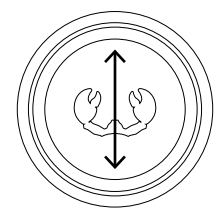

ΜΕΙΩΣΗ ΕΝΤΑΣΗΣ



ΤΕΛΟΣ ΚΛΗΣΗΣ

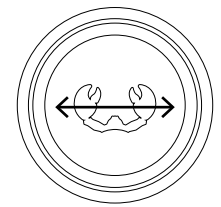

ΠΡΟΗΓΟΥΜΕΝΟ/ΕΠΟΜΕΝΟ



ΑΠΟΡΡΙΨΗ ΚΛΗΣΗΣ

## КНОПКИ

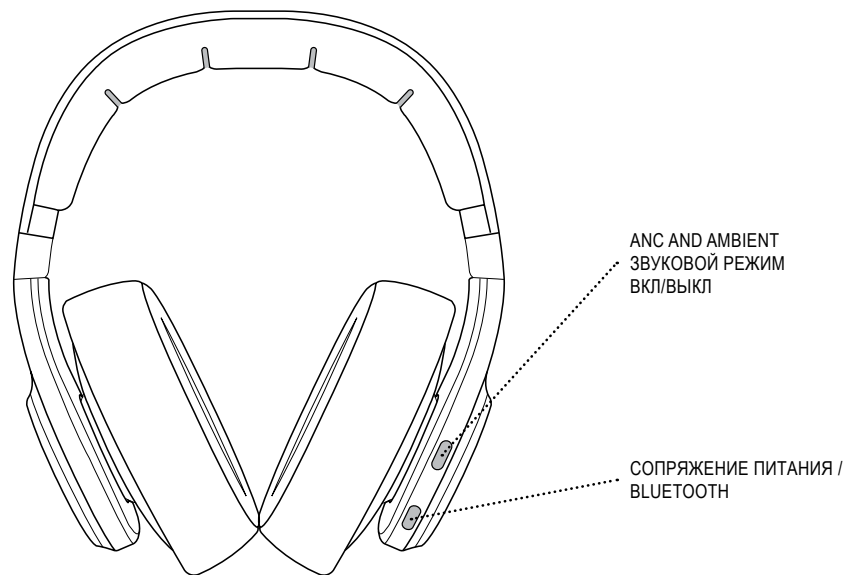

## СВЕТОДИОДЫ

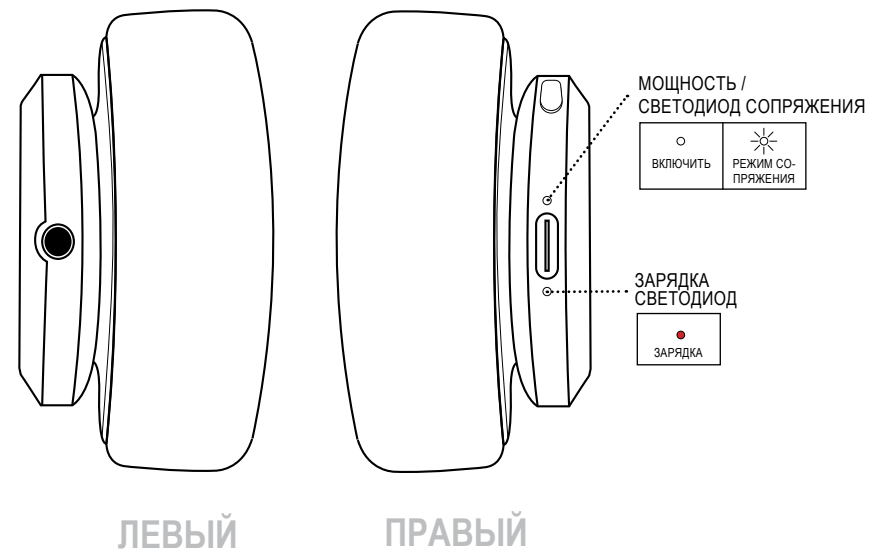

## ЗАПУСК В РАБОТУ

1.

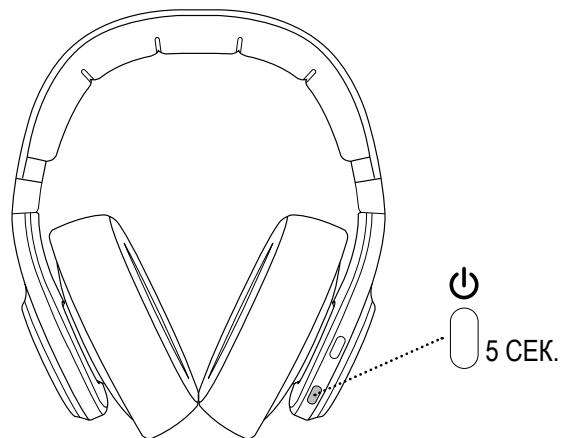

3.



2.



4.

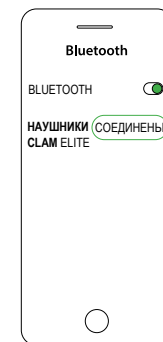

ОБЩЕЕ ИСПОЛЬЗОВАНИЕ - КАК  
ПОЛЬЗОВАТЬСЯ ANC

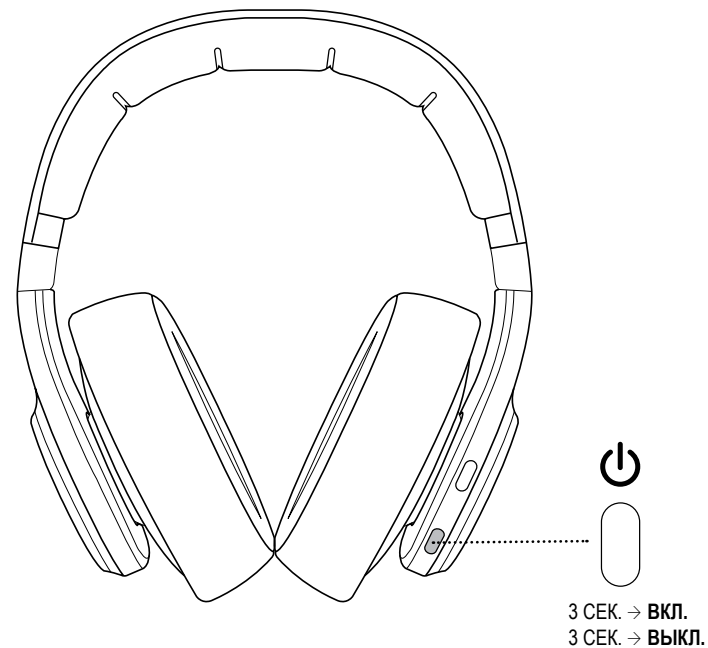
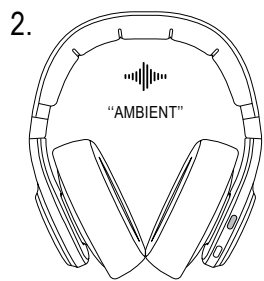
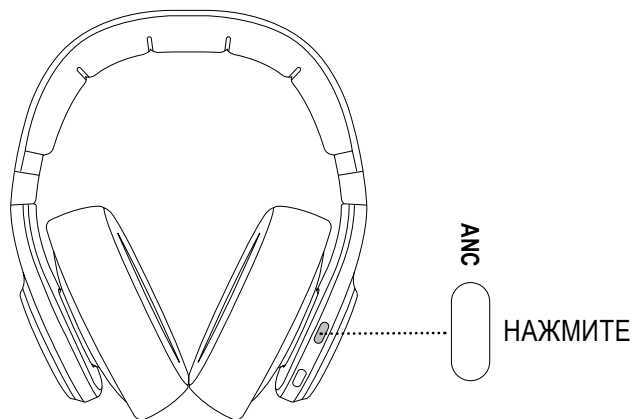

# МУЗЫКА И ТЕЛЕФОННЫЕ ЗВОНКИ



МУЗЫКА

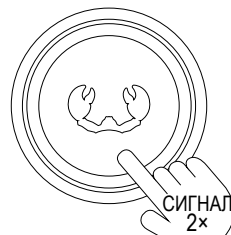

ВОСПРОИЗВЕДЕНИЕ / ПАУЗА

ТЕЛЕФОННЫЕ ЗВОНКИ

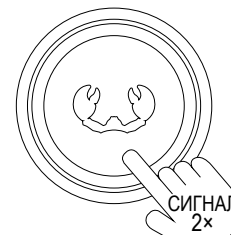

ПОЗВОНИТЬ

ГОЛОСОВОЙ ПОМОЩНИК



ГОЛОСОВОЙ ПОМОЩНИК

УВЕЛИЧИТЬ ГРОМКОСТЬ

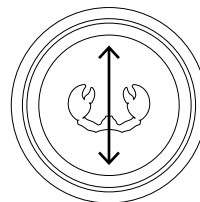

УМЕНЬШИТЬ ЗВУК

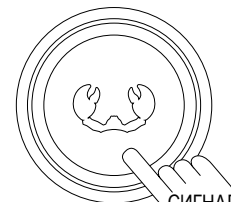

ЗАВЕРШИТЬ ЗВОНОК

ПРЕДЫДУЩИЙ / СЛЕДУЮЩИЙ

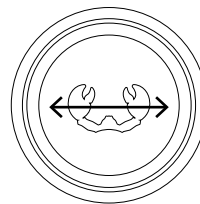

ОТКЛОНИТЬ ВЫЗОВ